

# **Model DRZ-PH<sup>TM</sup>** **Operating Instructions**

For 1-1/4" through 3" lines  
(30mm—75mm)



Your Model DRZ-PH is designed to give you years of trouble-free, profitable service. However, no machine is better than its operator.

Read, understand and follow all safety warnings and instructions provided with the product. Failure to follow the warnings and instructions may result in electric shock and/or serious injury. Save all warnings and instructions for future reference.

**SAVE THESE INSTRUCTIONS!**

***General***  
**PIPE CLEANERS**



**WARNING**

To reduce the risk of injury, user must read instruction manual. Failure to follow operating instructions could result in death or serious injury.

**WARNING Read all safety warnings and all instructions.** Failure to follow the warnings and instructions may result in electric shock, fire and/or serious injury. **Save all warnings and instructions for future reference.**

Replacement manuals are available upon request at no charge, or may be downloaded from our website, [www.drainbrain.com](http://www.drainbrain.com). Instructional videos are available for download on our website, and may be ordered. If you have any questions or problems, please call General's customer service department at 412-771-6300.

**Save all warnings and instructions for future reference.**

**These instructions are intended to familiarize all personnel with the safe operation and maintenance procedures for the Model DRZ-PH.**

**SAFETY SYMBOLS**

	This is the safety alert symbol. It is used to alert you to potential personal injury hazards. Obey all safety messages that follow this symbol to avoid possible injury or death.
--	--

**DANGER**

DANGER indicates a hazard with a high level of risk which, if not avoided, will result in death or serious injury.

**WARNING**

WARNING indicates a hazard with a medium level of risk which, if not avoided, could result in death or serious injury.

**CAUTION**

CAUTION indicates a hazard with a low level of risk which, if not avoided, will result in minor or moderate injury.

**WARNING**



Electric shock resulting in death can occur if you plug this machine into an improperly wired outlet. If the ground wire is electrified, you can be electrocuted by just touching the machine, even when the power switch is off. A ground fault circuit interrupter will not protect you in this situation. Use a UL listed tester to determine if the outlet is safe.



Do not operate power tools in explosive atmospheres, such as in the presence of flammable liquids, gases, or dust. Power tools create sparks which may ignite the dust or fumes.



Only wear leather gloves. Never use any other type of glove, such as cloth, rubber, or coated gloves. Never grasp a rotating cable with a rag. These items could become wrapped around the cable and cause serious injury.

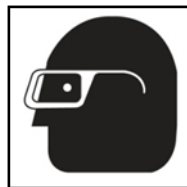

Always wear safety glasses and rubber soled, non-slip shoes. Use of this safety equipment may prevent serious injury.



Do not overstress cables. Overstressing cables may cause twisting, kinking, or breaking of the cable and may result in serious injury.

**WARNING**

This product can expose you to chemicals including lead, which is known to the State of California to cause cancer and birth defects or other reproductive harm. For more information go to [www.P65Warnings.ca.gov](http://www.P65Warnings.ca.gov).

## GENERAL SAFETY RULES



### WARNING

Read and understand all instructions. Failure to follow all instructions listed below may result in electric shock, fire, and/or serious injury.

### SAVE THESE INSTRUCTIONS!

#### Work Area

1. **Keep work area clean and well lit.** Cluttered benches and dark areas invite accidents.
2. **Do not operate power tools in explosive atmospheres, such as in the presence of flammable liquids, gases, or dust.** Power tools create sparks which may ignite the dust or fumes.
3. **Keep bystanders, children, and visitors away while operating a power tool.** Distractions can cause you to lose control.

#### Electrical Safety

1. **Grounded tools must be plugged into an outlet, properly installed and grounded in accordance with all codes and ordinances. Never remove the grounding prong or modify the plug in any way. Do not use any adapter plugs. Check with a qualified electrician if you are in doubt as to whether the outlet is properly grounded.** If the tool should electrically malfunction or break down, grounding provides a low resistance path to carry electricity away from the user.
2. **Avoid body contact with grounded surfaces such as pipes, radiators, ranges and refrigerators.** There is an increased risk of electric shock if your body is grounded.
3. **Do not expose power tools to rain or wet conditions.** Water entering a power tool will increase the risk of electric shock.
4. **Do not abuse the cord. Never use the cord to carry the tools or pull the plug from an outlet. Keep cord away from heat, oil, sharp edges or moving parts. Replace damaged cords immediately.** Damaged cords increase the risk of electric shock.
5. **When operating a power tool outside use an outdoor extension cord marked "W-A" or "W".** These cords are rated for outdoor use and reduce the risk of electric shock.
6. **Test the Ground Fault Circuit Interrupter (GFCI) provided with the power cord to insure it is operating correctly before operating machine.** Machine must have a properly functioning ground fault circuit interrupter on the power cord. GFCI reduces the risk of electric shock.
7. **Extension cords are not recommended unless they are plugged into a Ground Fault Circuit Interrupter (GFCI) found in circuit boxes or outlet receptacles.** The GFCI on the machine power cord will not prevent electric shock from the extension cords.
8. **Only use proper three-wire extension cords in good condition which have three-prong grounding plugs and three-pole receptacles which accept the tool's plug.** Use of damaged, inferior, or other extension cords will not ground the tool. Increases the risk of electric shock and bodily injury or death.
9. **Keep all electric connections dry and off the ground.** Reduces the risk of electric shock.
10. **DO NOT touch plugs or tools with wet hands.** Reduces the risk of electric shock.

#### Personal Safety

1. **Stay alert, watch what you are doing and use common sense when operating a power tool. Do not use tool while tired or under the influence of drugs, alcohol, or medication.** A moment of inattention while operating power tools may result in serious personal injury.
2. **Dress properly. Do not wear loose clothing or jewelry. Contain long hair. Keep your hair, clothing, and gloves away from moving parts.** Loose clothes, jewelry, or long hair can be caught in moving parts.
3. **Avoid accidental starting. Be sure switch is off before plugging in.** Carrying tools with your finger on the switch or plugging in tools that have the switch on invites accidents.
4. **Remove adjusting keys or wrenches before turning the tool on.** A wrench or key that is left attached to a rotating part of the tool may result in personal injury.
5. **Do not overreach. Keep proper footing and balance at all times.** Proper footing and balance enables better control of the tool in unexpected situations.
6. **Use safety equipment. Always wear eye protection.** Dust mask, non-skid safety shoes, hard hat, or hearing protection must be used for appropriate conditions.

#### Tool Use and Care

1. **Use clamps or other practical way to secure and support the workpiece to a stable platform.** Holding the work by hand or against your body is unstable and may lead to loss of control.
2. **Do not force tool. Use the correct tool for your application.** The correct tool will do the job better and safer at the rate for which it is designed.
3. **Do not use tool if switch does not turn it on or off.** Any tool that cannot be controlled with the switch is dangerous and must be repaired.
4. **Disconnect the plug from the power source before making any adjustments, changing accessories, or storing the tool.** Such preventative safety measures reduce the risk of starting the tool accidentally.
5. **Store idle tools out of reach of children and other untrained persons.** Tools are dangerous in the hands of untrained users.
6. **Maintain tools with care. Keep cutting tools sharp and clean.** Properly maintained tools, with sharp cutting edges are less likely to bind and are easier to control.
7. **Check for misalignment or binding of moving parts, breakage of parts, and any other condition that may affect the tool's operation. If damaged, have the tool serviced before using.** Many accidents are caused by poorly maintained tools.
8. **Only use accessories that are recommended by the manufacturer for your model.** Accessories that may be suitable for one tool may become hazardous when used on another tool.

#### Service

1. **Tool service must be performed only by qualified repair personnel.** Service or maintenance performed by unqualified repair personnel could result in risk of injury.
2. **When servicing a tool, use only identical replacement parts. Follow instructions in the Maintenance section of this manual.** Use of unauthorized parts or failure to follow Maintenance instructions may create a risk of electric shock or injury.

## SPECIFIC SAFETY RULES



This is the safety alert symbol. It is used to alert you to potential personal injury hazards. Obey all safety messages that follow this symbol to avoid possible injury or death.



Electric shock resulting in death can occur if you plug this machine into an improperly wired outlet. If the ground wire is electrified, you can be electrocuted by just touching the machine, even when the power switch is off. A ground fault circuit interrupter will not protect you in this situation. Use a UL approved tester to determine if the outlet is safe.



**Do not overstress cables.** Overstressing cables may cause twisting, kinking, or breaking of the cable and may result in serious injury.

1. **Only wear leather gloves.** Never use any other type of glove, such as cloth, rubber, or coated gloves. Never grasp a rotating cable with a rag. These items could become wrapped around the cable and cause serious injury.
2. **Never operate machine with motor cover removed.** Fingers can get caught between belt and pulley and there is potential for electrical shock.
3. **Do not overstress cables.** Keep leather-gloved hand on the cable for control when machine is running. Overstressing cables because of an obstruction may cause twisting, kinking, or breaking of the cable and may result in serious injury.
4. **Place the machine at a distance not greater than two feet from the opening.** Greater distances can result in cable twisting or kinking.
5. **Machine is designed for ONE-PERSON operation.** Operator must control foot switch and cable.
6. **Do not operate machine in reverse (REV).** Operating machine in reverse can result in cable damage and is used only to back cutting tool out of an obstruction.
7. **Keep hands away from rotating drum.** Do not reach into drum unless machine is unplugged. Hand may be caught in the moving parts resulting in serious injury.
8. **Be careful when cleaning drains where cleaning chemicals have been used.** Avoid direct contact with skin and eyes. Drain cleaning chemicals can cause serious burns as well as damage the cable.
9. **Do not operate machine if operator or machine is standing in water.** Will increase risk of electrical shock.
10. **Wear safety glasses and rubber soled, non-slip shoes.** Use of this safety equipment may prevent serious injury.
11. **Before starting each job, check that the cable in the drum is not broken or kinked, by pulling the cable out and checking for wear or breakage.** Always replace worn out (kinked or broken) cables with genuine GENERAL replacement cables.
12. **Only use this tool in the application for which it was designed. Follow the instructions on the proper use of the machine.** Other uses or modifying the drain cleaner for other applications may increase risk of injury.
13. **Do not operate machine if warning labels are missing or illegible.**

## FEATURES - Closed Drum Model DRZ-PH

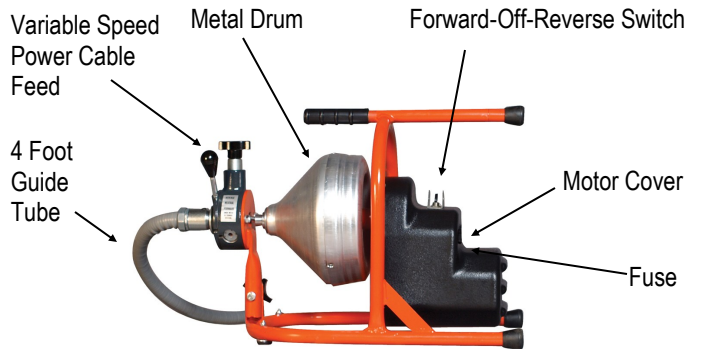





**Cable Application Chart (Table 1)**

Cable Size	Pipe Size	Typical Applications
1/4"	1-1/4" to 2"	Small lines, tubs, and shower drains.
5/16"	1-1/2" to 2"	Sinks, basins, and small drains.
3/8"	2" to 3"	Stacks, toilets, small drains (Not Roots).

The 1/4" and 5/16" diameter cables with EL Basin plug heads can be spun through most strainers and work well in lines blocked by soft stoppages such as hair, soap, fats, etc.

Maximum Capacity: 50 ft. of 1/4" or 5/16" cable, or 35 ft. of 3/8" cable.

**Cutter Application Chart (Table 2)**

Cutter	Catalog #	Typical Applications
Arrow Head 	AH	Ideal for heavy cutting and scraping.
Flexible Arrow Head 	FAH	More flexibility than Arrow Head; can take sharp turns in small lines.
Boring Gimlet 	BG	To remove or retrieve loose objects.
Down Head Boring Gimlet 	DHBG	Leads cable down drain line rather than up vent or across tee.
1-1/4" Side Cutter 	1-1/4SCB	Works well in grease stoppages, scrapes walls of pipe.

## OPERATION

### SET-UP



**DISCONNECT MACHING FROM POWER SOURCE BEFORE ATTACHING CUTTER!**

- Position the machine at a distance not greater than two feet (.6m) from drain opening so that the Guide Tube can be placed into the drain opening without excessive bending of the Guide Tube. If your model does not have a guide tube, or if you cannot get this close to the drain, run the cable through a hose or pipe to prevent cable whipping.

Note: Avoid sharp bends or kinking of the Guide Tube by repositioning the machine. The Model DRZ-PH is designed to be positioned either horizontally or vertically to facilitate this.

- The cable may have an EL-Basin plug head on the end to help the cable around tight bends, or it may have a female connector for attaching cutters. (See Cable Application Chart to select the correct cable size for the job.)
- To attach a cutter, first unplug the machine. Then, remove the screw and lock washer from the connector at the end of the cable. Slide the cutter into the slot, then replace the lock washer and connecting screw. Tighten the screw firmly.
- The Boring Gimlet and Arrow Head are good cutters to start with. Change to the larger cutters after you've gotten the water flowing.

- Plug the machine into a properly grounded outlet.
- Make sure the Forward/Off/Reverse switch is in the FORWARD position.
- Tighten the feed pressure knob on top of the variable speed power cable feed so that the feed roller presses against the cable. Be sure not to over tighten since this could cause excessive cablewear.
- The feed lever controls the feeding rate and direction of the cable. Move the feed lever down to feed the cable out of the drum. The farther the lever is moved downward, the faster the cable will feed out. Move the lever up to retract the cable into the drum. When the lever is in the middle (neutral) position, the cable will spin in place.

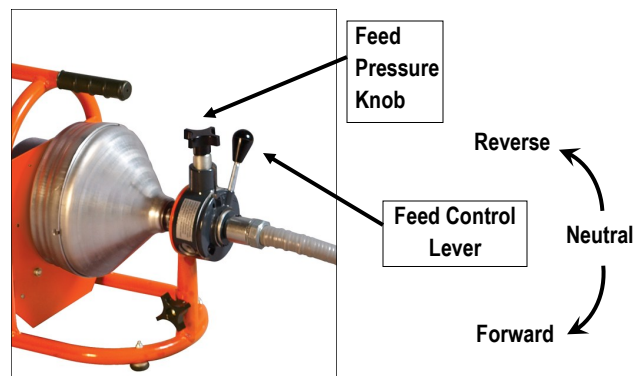

- Place the Guide Tube with the cable end and cutter protruding from the end of the Tube into the drain opening.
- With one gloved hand on the Guide Tube and one on the feed control lever, start the machine by stepping on the foot pedal.
- Move the feed control lever downward. Feed the cable slowly. Use the feed lever to adjust feeding speed as resistance is met. Don't feed faster than the cable can go into the drain. Too much cable between the guide tube and drain will cause whipping and kinking.



**DO NOT ALLOW TOO MUCH SLACK IN THE CABLE BETWEEN MACHINE AND DRAIN OPENING SINCE THIS CAN CAUSE CABLE WHIPPING.**

- If the cable starts to bend or twist, take your foot off the pedal and rotate the drum in the opposite direction to relieve the twist on the cable. Push any excess cable back into the drum and then continue.
- When the cable reaches the stoppage, put the feed in neutral. Then feed the cable slowly, chewing into the stoppage as it goes. This slow forward movement will reduce stress on the cable while doing a more thorough cleaning job. A back and forth action usually works best.

---

**DO NOT USE TOO MUCH FORCE – LET THE CUTTER DO THE WORK.**

---

14. When the stoppage is cleared, retract the cable by moving the feed lever into the reverse position. Keep the motor in the **forward** position.

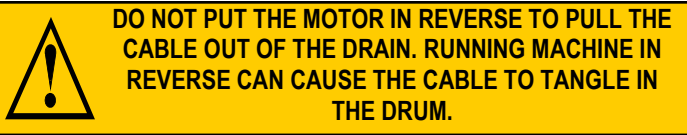

**Hint:** It's often helpful to have a small stream of water running in the line to wash the cuttings away while the machine is in operation and after.

## SPECIAL OPERATION

### IF CABLE GETS CAUGHT IN LINE

The motor can be reversed to free the cable if it gets caught in the line. Use the following procedure:

1. Move the motor switch to the Reverse position.
2. Push feed lever down (forward) while drum is turning in reverse.
3. When the cable has been freed, move the motor switch to the **FORWARD** position.

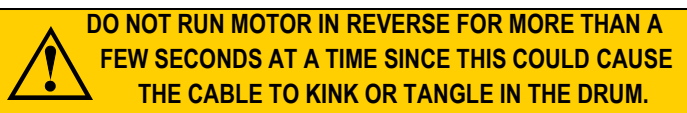

### TO CHANGE CABLE CARTRIDGES



1. Remove the cutter and connecting screw from the cable if one is attached.
2. Loosen the knob at the base of the front post and swing the front post and power cable feed forward.
3. Loosen the three screws around the outside of the drum that hold the front and back of the drum together.
4. Pull the drum front off the machine, revealing the cable cartridge within.
5. Pull the cable out of the feed and guide tube and slide it into the cable cartridge by hand.
6. Remove the cable cartridge.
7. Press replacement cartridge *firmly* into the back of the drum. Make sure to line up the grooves in the cartridge with the slots in the drum back.
8. Slide the cable through the drum front, Power Cable Feed, and guide tube.
9. Position the drum front so that the three screws align with the slots in the drum back. Press the drum front into the drum back and tighten the screws firmly, making sure the screws are centered in the slots and the heads are flush with the drum.
10. Swing the front post and feed back into position and tighten knob.

### IF CABLE TANGLES IN DRUM



This is caused by using too much pressure when feeding the cable or by feeding the cable while running in reverse.

1. To untangle, rotate the drum/cage in the opposite direction to relieve the twist.
2. If the cable has become badly tangled, disassemble the drum by loosening the screws around the rim of the drum and pull the drum front off the drum.
3. Pull the cable completely out of the drum. Then, reassemble the drum.
4. Straighten the cable out and push it back in the drum. (See "To Install Cable into Drum" below.)

### TO INSTALL CABLE IN DRUM



1. Loosen feed pressure knob so that the cable can pass through easily.
2. Push the back of the cable through the spout into the drum/cage.
3. Be certain that the cable goes into the drum as shown in the illustration, or the cable will tangle in the drum.
4. It will be easier to load the cable if you put a slight bend in the cable about one inch from the end.

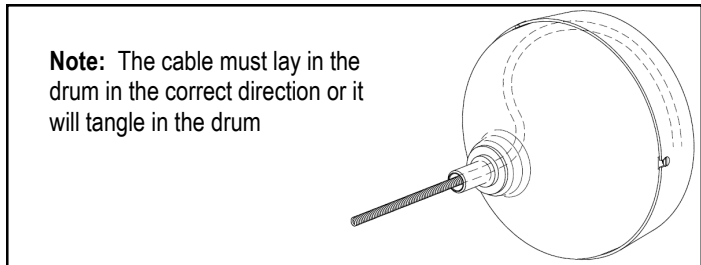

## MAINTENANCE



**DISCONNECT MACHINE FROM POWER SOURCE  
BEFORE PERFORMING MAINTENANCE!**

To keep your machine operating smoothly, it is essential that all bearings and bushings be lubricated. Oiling moving parts is particularly important where machine comes in contact with sand, grit and other abrasive material.

### CABLE MAINTENANCE

To get maximum service from your cables, be sure that they are clean and well oiled. This not only provides running lubrication but greatly extends the life of the cables as well. Some users periodically pour oil directly into the drum. Then, as the drum turns, the cables get complete lubrication. Our SNAKE OIL is ideally suited for this purpose, since it not only lubricates the cables, it deodorizes them as well.



### POWER FEED MAINTENANCE

Keep feed free of excessive soil and grit. It is recommended that the feed be flushed with fresh water followed by a light oiling of the moving parts. No disassembly is normally required. Failure to feed can usually be traced to the following possibilities:

### DIRT ACCUMULATION

Over time, dirt can harden enough to stop roller rotation. Flushing with water followed by liberal oiling can usually restore function. If disassembly is required, proceed as follows:

1. Remove the feed pressure knob, cover screws, top cover, ball bearing and ball bearing holder. Note the positioning of these parts to ease re-assembly. Remove the swing pin from the carrier. The top roller assembly can now be removed.
2. Remove the snap rings and thrust washers from the bottom housing cylinders. Remove swing pins from carriers. The bottom roller assemblies can now be removed.
3. Re-assembly is done in reverse order.

### TANGLED CABLE

If a cable loops over itself in the drum/cage, it will not feed properly. Remove and reload the cable to restore function. If the cable kinks, it is evidence of abuse and results from the use of too much pressure or use of the wrong size cable for the line. Do not force the cable — let the cutter do the work.

### DAMAGED ROLLER

Excessive use may wear a roller to the point of failure. It is recommended that all three rollers be replaced at the same time (Cat # PO-PH-703). The replacement roller is an assembly consisting of one Feed Roller Bearing and two Bearing Spacers.

**Note: The Bearing Spacers must be installed between the Carrier and each Feed Roller Bearing (as illustrated below) in order to ensure proper operation and to obtain maximum Feed Roller life.**

#### To Replace the Feed Roller Assembly:

1. Remove the Feed Roller Assembly by unscrewing and removing the Feed Roller Axle.
2. While holding the Feed Roller Assembly together, insert it into the slot opening of the Carrier.
3. In order to help align the Spacers and Bearings, insert a pencil point or similar object through the **un-threaded** end of the Axle hole in the Carrier. After removing the pencil point, continue to maintain the alignment of the components.
4. The Feed Roller Axle should then be inserted through the same hole and should continue to be guided through the Spacers and Bearings to the Axle hole on the other side of the Carrier.

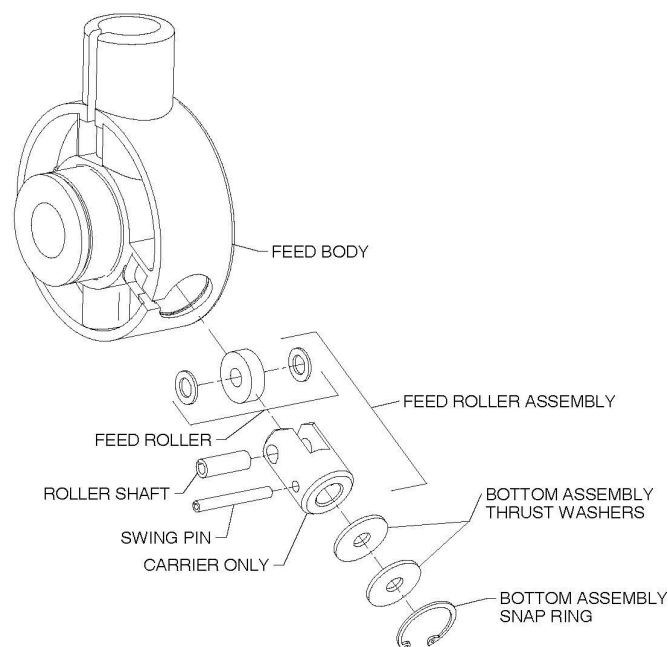

**TROUBLE SHOOTING GUIDE (TABLE 3)**

<b>Problem</b>	<b>Probable Cause</b>	<b>Solution</b>
Cable kinks or breaks.	Operator forcing the cable.	Do not force the cable. Let the cutter do the work.
	Too much slack between machine and drain.	Do not allow more than six inches between guide hose and drain.
	Cable used in wrong size drain line.	A cable that is too large or too small in diameter for a line is more likely to kink (See Table 1—Cable Application Chart).
	Cable exposed to acid.	Clean and oil cables regularly.
Cable tangles in drum/cage.	Operator forcing the cable.	Do not force the cable. Let the cutter do the work.
	Machine run in reverse.	Do not run machine in reverse to retract cable from drain. Use reverse only if cable is caught in line.
Drum/cage stops while foot pedal depressed.	Hole in pedal or hose.	Replace as required.
	Hole in diaphragm switch.	If no hole found in pedal or hose, replace diaphragm switch.
	Blown fuse.	Replace with a 5 amp fuse (if 120 v motor) or 3 amp fuse (if 220 v motor).
Motor turns in one direction but not other.	Reverse switch failure.	Replace reverse switch.
Ground fault circuit interrupter trips and will not reset.	Damaged power cord or extension cord.	Replace cords.
	Short circuit in motor.	Take machine to authorized repair center.
	Faulty ground fault circuit interrupter.	Replace ground fault circuit interrupter.
Failure to feed.	Cable tangled in drum.	Make sure to use proper size cable for the job (see Table 1 – Cable Application Chart).
	Feed misadjusted.	If feed tension knob is too loose, the cable will slip. If it is too tight, the feed rollers will wear prematurely.
	Frozen or worn rollers.	Clean debris from around rollers. If rollers do not turn, cable will not feed. Badly worn rollers must be replaced.
	Worn cable.	When cable coils wear flat, cable should be replaced.

THIS PAGE INTENTIONALLY LEFT BLANK

THIS PAGE INTENTIONALLY LEFT BLANK

THIS PAGE INTENTIONALLY LEFT BLANK

**General Wire Spring Co,  
1101 Thompson Avenue  
McKees Rocks, PA 15136  
412-771-6300      [www.drainbrain.com](http://www.drainbrain.com)**