

## Flexi-Router 100 PARTS LIST

ITEM NO.		DESCRIPTION	ITEM NO.		DESCRIPTION
1	107260	Frame w/ (2) 10" Wheels, (2) Wheel Caps, (2) Wheel Spacers, (4) 1/2" Washers & 8-32 x 5/16 Long Ground Screw, includes:	90	107220	Safety Slip Clutch, includes:
1-A	107280	Reel Shaft	90-A	107545	Body w/ Clamp & (8) 8-32 x 5/8" Long Screws
1-B	107080	(5) Rubber Leg Tips	90-B	107550	Pressure Plate, Stem & 1/4-28 x 5/8" Long Screw
1-C	107300	(2) Round Tube Plugs	90-C	107555	Friction Disc
15	107310	10" Wheel, includes:	90-D	107560	Cover
15-A	107240	Wheel Cap, Spacer & (2) 1/2" Washers	90-E	107565	Pressure Spring Kit
25	107250	Handle, includes:	90-F	107800	Set of 3/8-24 Jam Nuts
25-A	107340	(2) Handle Hinges & (2) 5/16-18 x 7/8" Long Bolts	100	107805	Reel Retaining Collar w/ (3)10-32 x 3/8" Long Set Screws
25-B	107350	(2) 3/8-16 Handle Knobs	105	107810	Slip Ring w/ (3) 8-32 x 3/8" Long Screws & (3) No. 8 Lock Washers
35	107360	Cable Retainer, includes:	110	107815	Slip Ring Cover w/ (3) 1/4-20 x 7/16" Long Set Screws
35-A	107370	(4) 1/4-20 x 2-1/4" Long Screws & (4) 1/4-20 Nut	115	107820	Power Switch w/ Wiring Diagram
35-B	107380	(6) Rectangular Tube Plugs	120	106810	50' Flexible Shaft Assembly (includes 107150, 106660)
35-C	107390	(10) Cable Retainer 1/4" Spacer Washers	125	106820	25' Flexible Shaft Assembly (includes 107150, 106660)
45	107400	Control Box w/ (4) 10-32 x 3/8" Long Mounting Screws & Grommet	130	107150	Flexible Shaft Coupler w/ (4) 8-32 x 3/8" Long Screws & Thrust Washer
50	136080	Power Switch Diaphragm	135	107825	(8) 8-32 x 3/8" Long Screws for Flexible Shaft Coupler
55	107000	20 ft. Power Cord w/GFCI	140	107535	(4) Thrust Washers
60	136170	Foot Pedal & Hose	145	106660	Flexible Sheath End Assembly
65	107410	Set of Reel Spacer Washers, includes:	150	126890	1-1/2" ClogChopper Cutter w/ Leader & (2) M6 x 1 mm x 6 mm Long Set Screws
		Thick Washer, (4) Thin Washers & Thrust Washer	155	106900	2" Chain Cutter for PVC w/ Leader & (4) M5 x 0.8 mm x 5 mm Long Set Screws
70	107430	Reel, includes:	160	106830	2" Heavy-Duty Carbide Tipped Chain Cutter w/ Leader & (4) M5 x 0.8 mm x 5 mm Long Set Screws
70-A	107440	Back Plate, includes:	165	106840	3"-4" Chain Cutter for PVC w/ Leader, Leader Protector, & (6) M6 x 1 mm x 6 mm Long Set Screws
70-B	107450	Foam Pad	170	106890	3"-4" Heavy-Duty Carbide Tipped Chain Cutter w/ Leader, Leader Protector, & (6) M6 x 1 mm x 6 mm Long Set Screws
70-C	107460	(2) Bearings	175	106930	3" Circular Carbide Tipped Chain Cutter w/ Leader & (2) M6 x 1mm x 6mm Long Set Screws
70-D	107470	Rings (Large & Small)	180	106940	4" Circular Carbide Tipped Chain Cutter w/ Leader & (2) M6 x 1mm x 6mm Long Set Screws
70-E	107270	(15) Rods & (30) 10-32 x 5/8" Long Screws	185	107830	(5) 3-4" Chain Cutter Leaders & (5) Leader Protectors
70-F	107490	Brake Lever	190	107835	(5) 2" Chain Cutter Leaders
70-G	107500	(2) Cord Clamps w/ (2) 10-32 x 5/8" Long Screws & (2) 10-32 Nuts	195	107840	(5) ClogChopper & Circular Chain Cutter Leaders
70-H	107510	Sheath Clamp & (2) 1/4-20 x 3/4" Long Screws	200	107845	(12) M6 x 1 mm x 6 mm Long Set Screws for 1-1/2" ClogChopper, 3-4" Chain, & Circular Chain Cutters
70-I	107515	Sheath Guide & (2) 1/4-20 x 3/4" Long Screws	205	107850	(8) M5 x 0.8 mm x 5 mm Long Set Screws for 2" Stainless Steel Chain Cutters
70-J	107525	Drill Clamp Strap w/ 5/16-18 Speed Control Knob, (2) 1/4-20 x 3/4" Long Screws, (2) 1/4-20 Nuts & (2) 1/4" Washers	210	131340	Cutter Bag
75	107200	Variable Speed Motor (Makita) w/ Motor Spacer & M8 x 1.25 mm x 25 mm Long Screw	215	107860	9/64", 3 mm, 2.5 mm Allen Wrench Set
80	107530	Clutch Guard w/ (4) 10-32 x 5/8" Long Screws & (4) 10-32 Nuts	220	106790	Flexi-Router Lube (8 Oz Tub)

# FLEXI-ROOTER 100 SCHEMATIC DIAGRAM

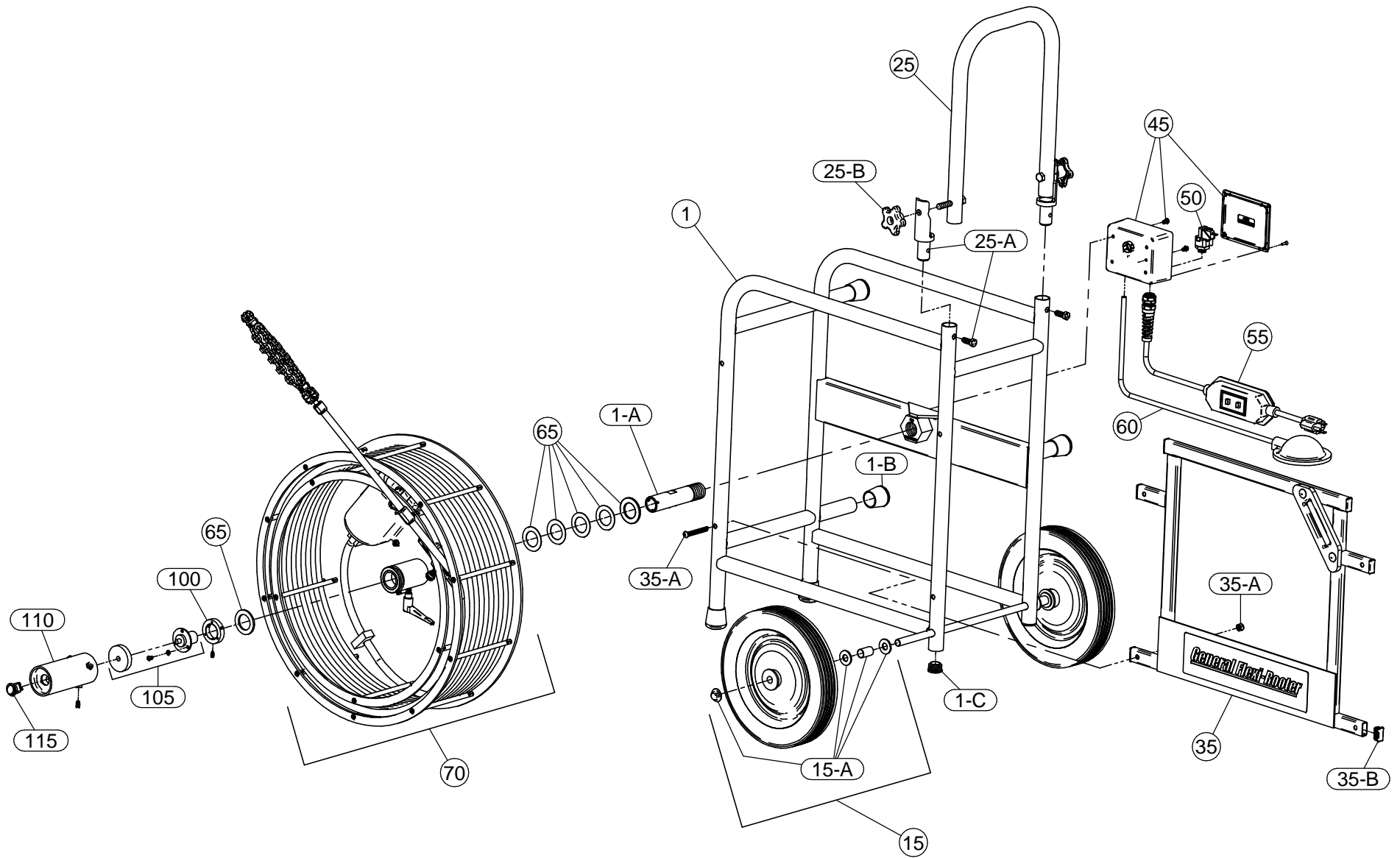

# FLEXI-ROOTER 100 SCHEMATIC DIAGRAM

