

MODEL DRZ PARTS LIST

ITEM NO.	CATALOG NO.	DESCRIPTION	ITEM NO.	CATALOG NO.	DESCRIPTION
157610	DRZ-100	Frame Complete for Quick Grip Chuck	157990	DRZ-300	Motor
157620	DRZ-101	Rubber Feet, Bolts, & Lock Nuts	158000	DRZ-301	Motor Nuts, Lock Washers, and Spacers
157640	DRZ-103	Rubber Leg Tip	158010	DRZ-500	Complete Motor Guard Assembly
157650	DRZ-104	Flanged Bushings	158020	DRZ-501	Motor Guard Only
157660	DRZ-105	Motor Ground Screw & Nut	158030	DRZ-502	Wiring Harness
157730	DRZ-152	Thrust Washer	158040	DRZ-502-A	Power Switch Diaphragm
157740	DRZ-153	4.5" Pulley	158050	DRZ-502-B	Foot Pedal w/Hose
157750	DRZ-154	V-Belt	158060	DRZ-502-C	Fuse Holder w/Fuse
157760	DRZ-155	Motor Mount Bracket	158070	DRZ-502-D	Fuse
157770	DRZ-155-A	Motor Mount Bracket Screws	158090	DRZ-502-E	Rectifier
157780	DRZ-156	Acorn Nuts and Washers	158100	DRZ-502-F	Rectifier Nut, Screw, & Washer
157800	DRZ-200-P	Plastic Drum Assembly w/Quick Grip Chuck	158110	DRZ-502-G	10' Power Cord w/GFCI
157830	DRZ-201-P	Plastic Drum Front	158120	DRZ-502-H	Switch
157840	DRZ-201-P-A	Screws for Plastic Drum	158130	DRZ-502-J	Switch Guard
157860	DRZ-202-P	Plastic Drum Rear	132210	DRZ-DECAL	Set of Safety Decals
157690	DRZ-206-P	Drum Shaft for Plastic Drum & Open Drum Cage	130010	HECS	Handylectric Cutter Set
157980	DRZ-208	Fender Washer	120020	50HE1	Flexicore Cable, 1/4" x 50 ft. with EL Basin Head
157895	DRZ-209	Quick Grip Chuck Grippers (3)	120100	50HE1-A-DH	Flexicore Cable, 5/16" x 50 ft. with Down Head
157910	DRZ-210	Quick Grip Chuck Knob	120130	50HE1-AC	Flexicore Cable, 5/16" x 50 ft. with Female Connector
157920	DRZ-211	Quick Grip Chuck Retaining Ring	120170	35HE2	Flexicore Cable, 3/8" x 35 ft. with Female Connector
157940	DRZ-250-O	Open Drum Cage Assembly for Quick Grip Chuck	140840	BNDT	Band-It Splashguard
157960	DRZ-251	Open Drum Cage Only for Quick Grip Chuck			
157870	DRZ-203	Drum Hub			
157890	DRZ-205	Screws and Nuts for Hub			

MODEL DRZ SCHEMATIC DIAGRAM

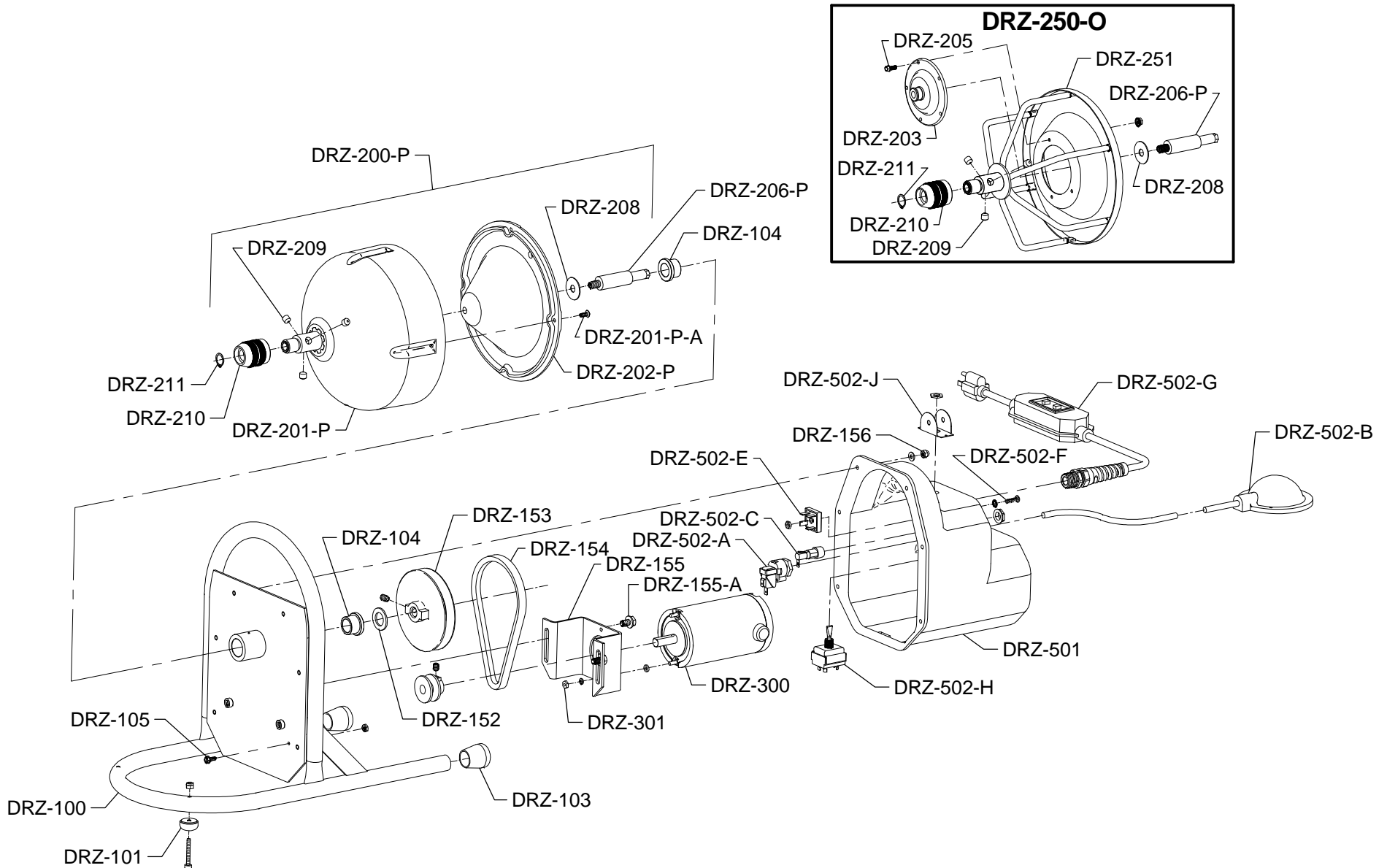

IMPORTANT: When ordering, give Serial Number of Machine.