

MODEL DRZ PARTS LIST

ITEM NO.	CATALOG NO.	DESCRIPTION	ITEM NO.	CATALOG NO.	DESCRIPTION
157610	DRZ-100	Frame Complete for Quick Grip Chuck	157940	DRZ-250-O	Open Drum Cage Assembly for Quick Grip Chuck
157620	DRZ-101	Rubber Feet, Bolts, & Lock Nuts	157960	DRZ-251	Open Drum Cage Only for Quick Grip Chuck
157640	DRZ-103	Rubber Leg Tip	157870	DRZ-203	Drum Hub
157650	DRZ-104	Flanged Bushings	157890	DRZ-205	Screws and Nuts for Hub
157660	DRZ-105	Motor Ground Screw & Nut	157990	DRZ-300	Motor
157730	DRZ-152	Thrust Washer	158000	DRZ-301	Motor Nuts and Lock Washers
157740	DRZ-153	4.5" Pulley	158010	DRZ-500	Complete Motor Guard Assembly
157750	DRZ-154	V-Belt	158020	DRZ-501	Motor Guard Only
157760	DRZ-155	Motor Mount Bracket	158030	DRZ-502	Wiring Harness
157770	DRZ-155-A	Motor Mount Bracket Screws	158040	DRZ-502-A	Power Switch Diaphragm
157780	DRZ-156	Acorn Nuts and Washers	158050	DRZ-502-B	Foot Pedal w/Hose
157800	DRZ-200-P	Plastic Drum Assembly w/Quick Grip Chuck	158060	DRZ-502-C	Fuse Holder w/Fuse
157830	DRZ-201-P	Plastic Drum Front	158070	DRZ-502-D	Fuse
157840	DRZ-201-P-A	Screws for Plastic Drum	158090	DRZ-502-E	Rectifier
157860	DRZ-202-P	Plastic Drum Rear	158100	DRZ-502-F	Rectifier Nut, Screw, & Washer
157690	DRZ-206-P	Drum Shaft for Plastic Drum & Open Drum Cage	158110	DRZ-502-G	10' Power Cord w/GFCI
157980	DRZ-208	Fender Washer	158120	DRZ-502-H	Switch
157895	DRZ-209	Quick Grip Chuck Grippers (3)	158130	DRZ-502-J	Switch Guard
157910	DRZ-210	Quick Grip Chuck Knob	132210	DRZ-DECAL	Set of Safety Decals
157920	DRZ-211	Quick Grip Chuck Retaining Ring			

MODEL DRZ SCHEMATIC DIAGRAM

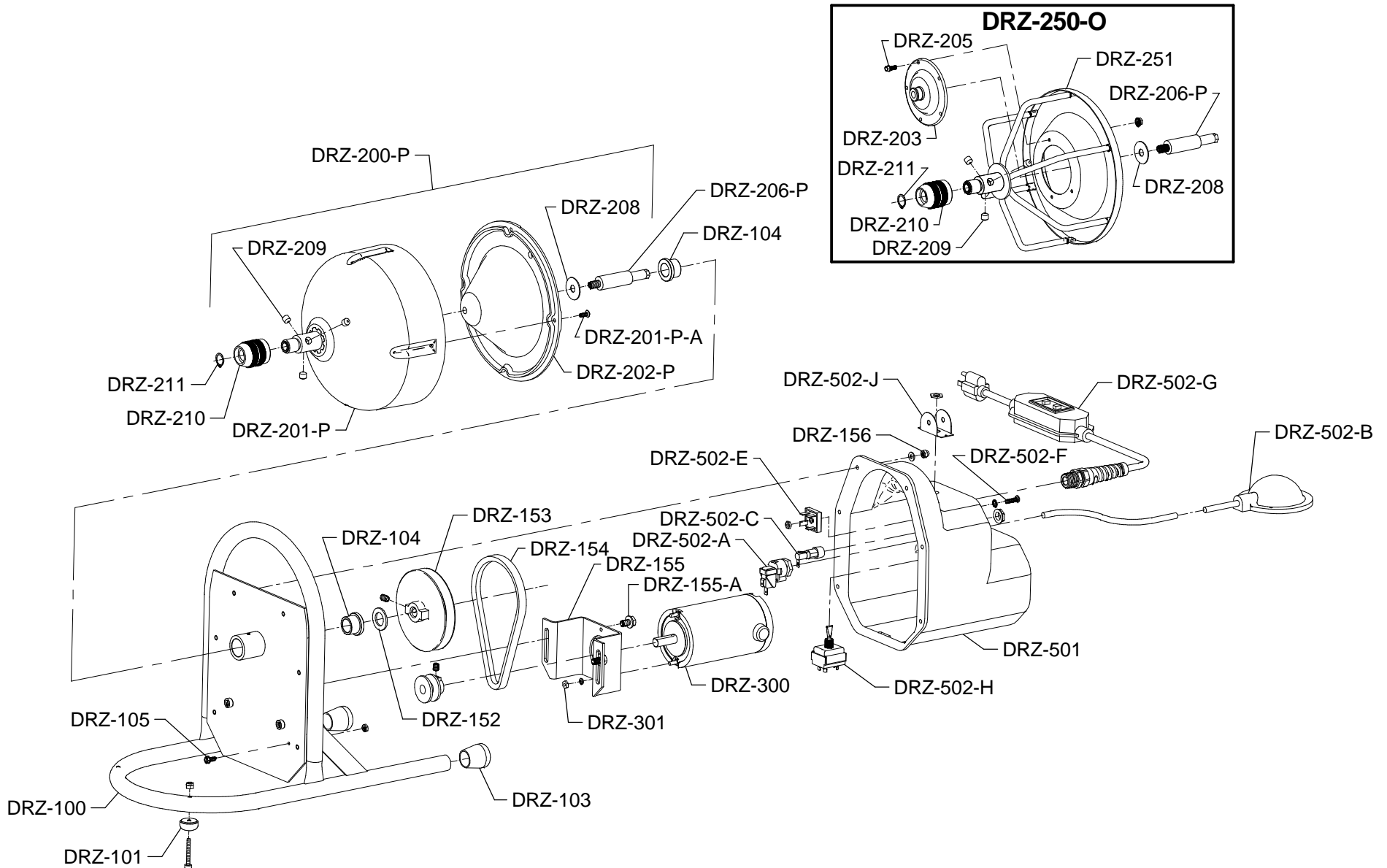

IMPORTANT: When ordering, give Serial Number of Machine.