

M:\Drawings\PRIVATE LABEL\GENERAL PIPE CLEANERS\JM-2512-0GH\JM-2512 - ANTIFREEZE PLUMBING.iam

NOTE: BOLTS (3), WASHERS (4), AND LOCKNUTS (5) ARE USED TO SECURE TANK BRACKETS TO TRAILER DECK

HAND CRANK HOSE REEL MOUNTED ON TOOLBOX AT REAR OF TRAILER

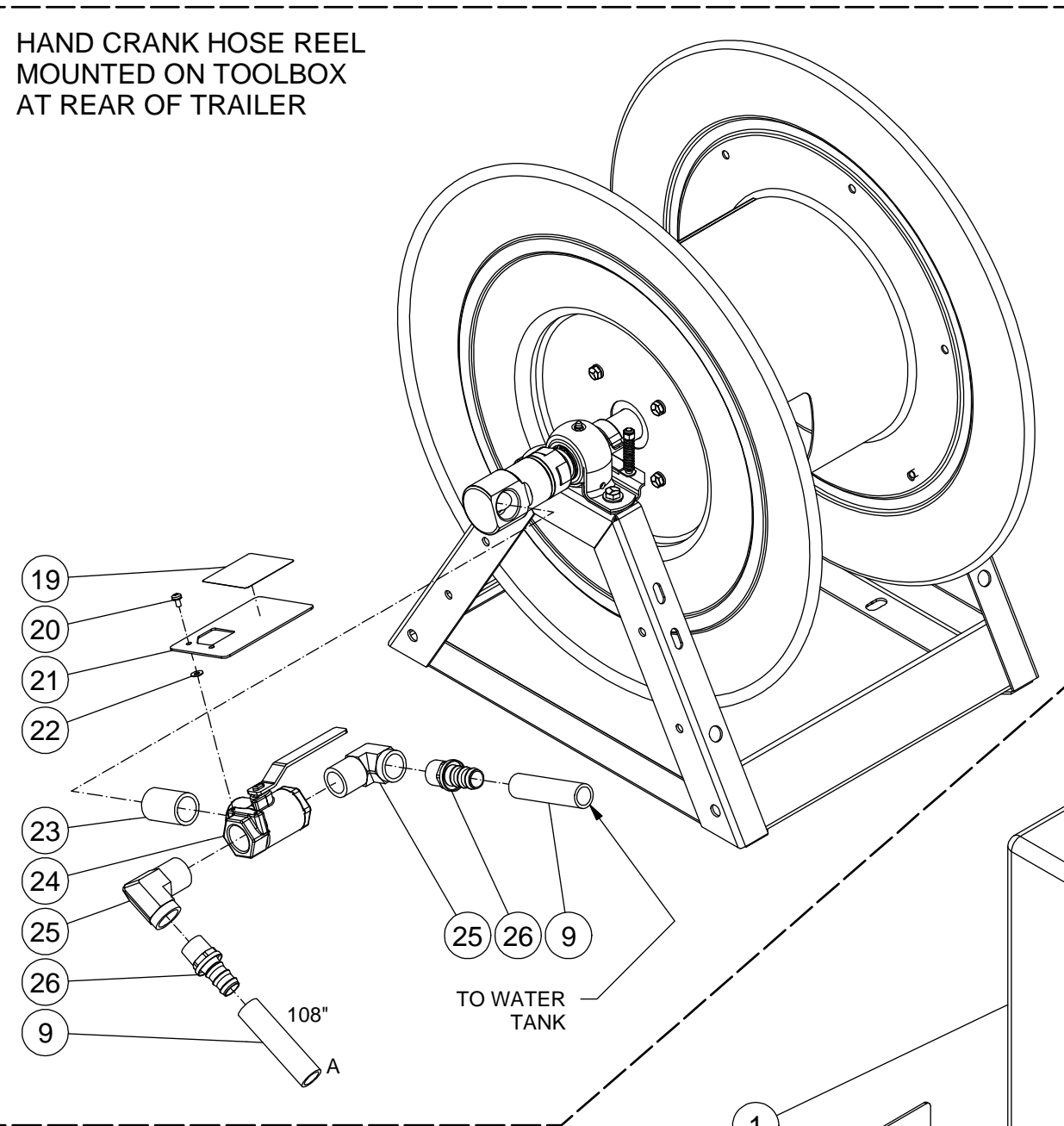

ITEM	DESCRIPTION	PART #	P/L	R/Q	QTY
1	TANK - 7 GALLON PLASTIC	12-0235			1
2	BRACKET - ANTIFREEZE TANK	20-1259A18			2
3	BOLT - HHCS - ZI GR5 5/16-18 x 1"	27-0067			4
4	WASHER-ZI SAE TYPE A 5/16"	28-0003			8
5	HEX NYLON LOCKNUT-ZINC 5/16-18	30-0157			4
6	BULKHEAD FITTING 3/4	55-0010			2
7	BARB - 3/4"MNPT X 3/4" BARB	23-0482			3
8	CLAMP WORM #20SS 3/4 - 1-1/2	42-0018			2
9	HOSE - 3/4" ID CLEAR REINFORCED	15-0304		???	1
10	BALL VALVE 3/4 - BRASS	22-0279			1
11	NIPPLE 3/4M X 3/4M HEX - BRASS	23-0026			1
12	REDUCER - 1"MNPT X 3/4"FNPT	23-0473			1
13	BARB 1MP X 1 HOSE - BRASS	23-0091		X	2
14	FILTER 1" WYE IN LINE 80 MESH	19-0247		X	1
15	TEE - 1" STREET GALVANIZED	24-0117			1
16	1" PIPE WELDMENT	20-0951A01		X	1
17	BALL VALVE 1"NPT BRASS STD	22-0344		X	1
18	DECAL - ANTIFREEZE ONLY	34-2648	N/A	X	1
19	DECAL - TANK SELECTION	34-2698	N/A	X	1
20	PPHMS #10-24 X 3/8	27-9533			2
21	3-WAY BALL VALVE COVER	20-1285A01			1
22	FLATWASHER - 3/16 ZINC	28-0001			2
23	NIPPLE - 1" NPT X 2" LONG	24-0324			1
24	BALL VALVE-3 WAY 1"NPT BRONZE	22-0321			1
25	ELBOW - 1" MNPT X 3/4" FNPT	24-0322			2
26	BARB 3/4" MALE X 3/4" LOCK - BRASS	23-0008			2

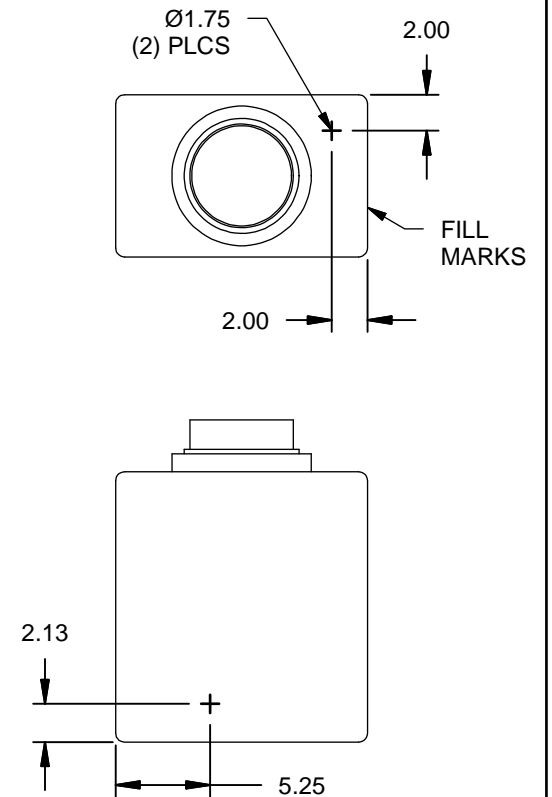
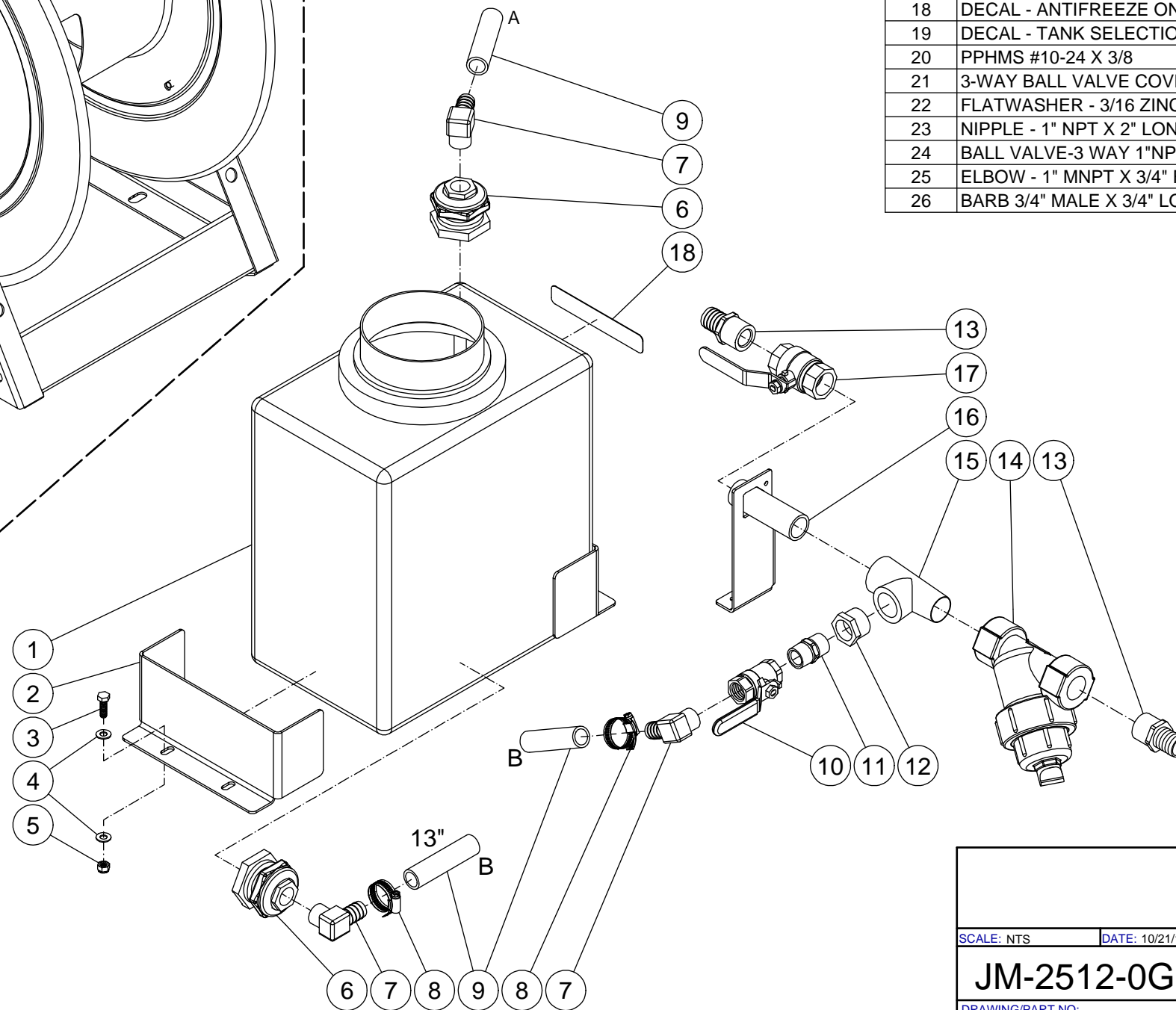

SCALE: NTS	DATE: 10/21/11	DRAWING SIZE: B	APPD:	DRAWN BY: CH
JM-2512-0GH - ANTIFREEZE PLUMBING				
DRAWING/PART NO: JM-2512 - ANTIFREEZE PLUMBING				

M:\Drawings\PRIVATE LABEL\GENERAL PIPE CLEANERS\JM-2512-0GHJM-2512 - GUN_WAND_HOSE ASSY.iam

ITEM	DESCRIPTION	PART #	P/L	R/Q	QTY
1	3/8" FNPT X M22 SCREW COUPLER	23-0490			1
2	HOSE - 3/8 X 50' 4500 PSI	15-0166			1
3	TRIGGER GUN 4000 PSI	16-0001			1
4	DUAL LANCE - 48.00"	16-0417			1
5	NOZZLE 2514 1/4" MEG	18-0431			1

SHIP WITH				
ITEM	DESCRIPTION	PART #	QTY	
-	JACK ROD	61-1036	1	
-	KEYS SET FOR TOOLBOX DOORS	-	2	
-	JM-2512 MANUAL		1	
-	NOZZLE SET - 1/2" JN-HP-150	18-0437	1	
-	DVD - JETTER INSTRUCTIONAL	37-1155	1	
-	WARRANTY REPLY CARD	37-1156	1	
-	CATALOG STUFFER - JET SET	37-1157	1	
-	WARRANTY TRI-FOLD	37-1158	1	
-	HONDA GX690 ENGINE MANUAL	-	1	

NOTES:

- ALL ITEMS ARE SHIPPED INSIDE THE TOOL BOX ON THE TRAILER
- INSTALL SCREW COUPLER (23-0490) & TRIGGER GUN (16-0001) ON HOSE ENDS
- PUT THREAD TAPE ON THREADS OF DUAL LANCE (16-0417); **DO NOT** INSTALL ONTO GUN--**SHIPS LOOSE**
- INSTALL NOZZLE (18-0431) ON DUAL LANCE

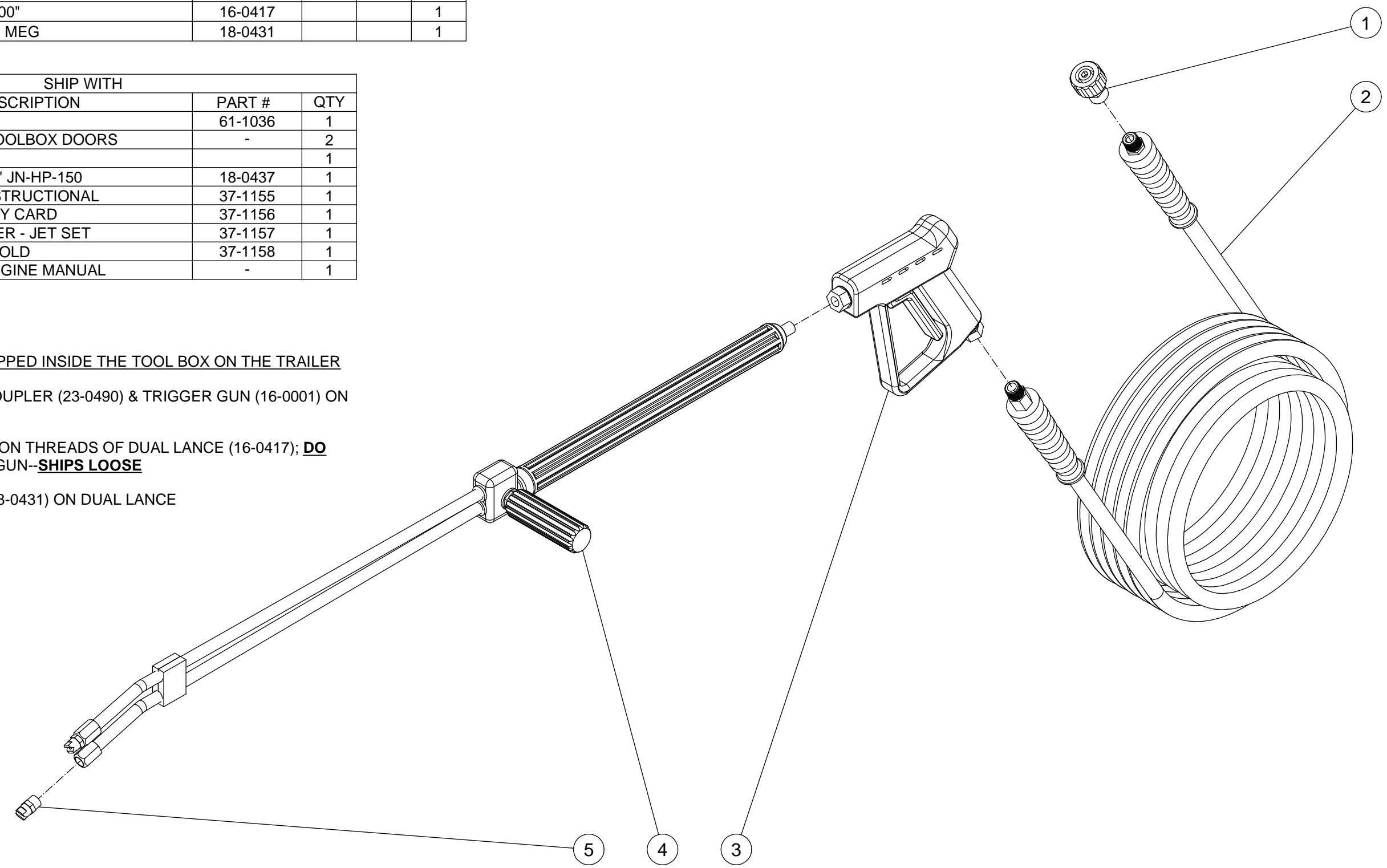

SCALE: NTS	DATE: 7/20/11	DRAWING SIZE: B	APPD:	DRAWN BY: CH
JM-2512 - GUN/WAND/HOSE ASSY				
DRAWING/PART NO: JM-2512 - GUN_WAND_HOSE ASSY				

M:\Drawings\PRIVATE LABEL\GENERAL PIPE CLEANERS\JM-2512-0GHJM-2512 - ENGINE CONTROL BOX.iam

ITEM	DESCRIPTION	PART #	P/L	R/Q	QTY
1	ENGINE CONTROL BOX	20-1250A01			1
2	EXTERNAL TOOTH LOCKWASHER	28-1009			12
3	HEX NUT - M5 X 0.8	30-6001			5
4	HHCS ZINC GR8.8 M5 - 0.80P x 25MM	27-8807			1
5	GROMMET 1/2 X 3/4 X 1/8	33-0001			5
6	LOCKNUT ELECT 3/4"	32-0292			1
7	CORD RELIEF - 3/4" NPT .750 CORD	9-0046			1
8	PPHMS - ZINC #8-32 X 5/8	27-8942			10
9	VARIABLE SPEED CONTROL - 12V DC	32-1100			1
10	THROTTLE CABLE - PUSH/PULL	33-0539			1
11	BOLT - HHCS - ZI GR5 5/16-18 x 1"	27-0067			4
12	LOCKWASHER-ZINC MED 5/16	29-0007			4
13	WASHER-ZI SAE TYPE A 5/16"	28-0003			4
14	ENVELOPE-ZIPLOCK/PLASTIC 6X6	41-0184			1
15	RELAY CONTROL 12 VDC	32-0791			1
16	PRHMS - #10-32 X 3/4 ZINC	27-8912			2
17	HEX NYLON LOCKNUT - SS M4 - .7P	30-8152			2
18	THROTTLE CONTROL	33-0514			1
19	HEX NYLON LOCKNUT-ZI #6-32	30-0152			2
20	EXTERNAL LOCKWASHER #6-32	29-1013			2
21	DECAL - ENGINE CONTROLS	34-2642	N/A	X	1
22	ENGINE CONTROL PANEL	20-1251A01			1
23	SWITCH - ROCKER W/ LAMP 12V	32-0969			1
24	PPHMS-BL OXIDE #6-32X3/4	27-8881			2
25	HOUR METER / DIGITAL	32-0668			1
26	PPHMS M4-0.7X16MM - SS	27-2770			2
27	KEY SWITCH (SEE ENGINE BREAKDOWN)	-	N/A	X	1
-	DECAL SET - JM-2512	71-0005			1

NOTE: BOLTS (11), LOCKWASHERS (12), AND WASHERS (13) ARE USED TO SECURE CONTROL BOX TO TRAILER DECK/ TOOLBOX

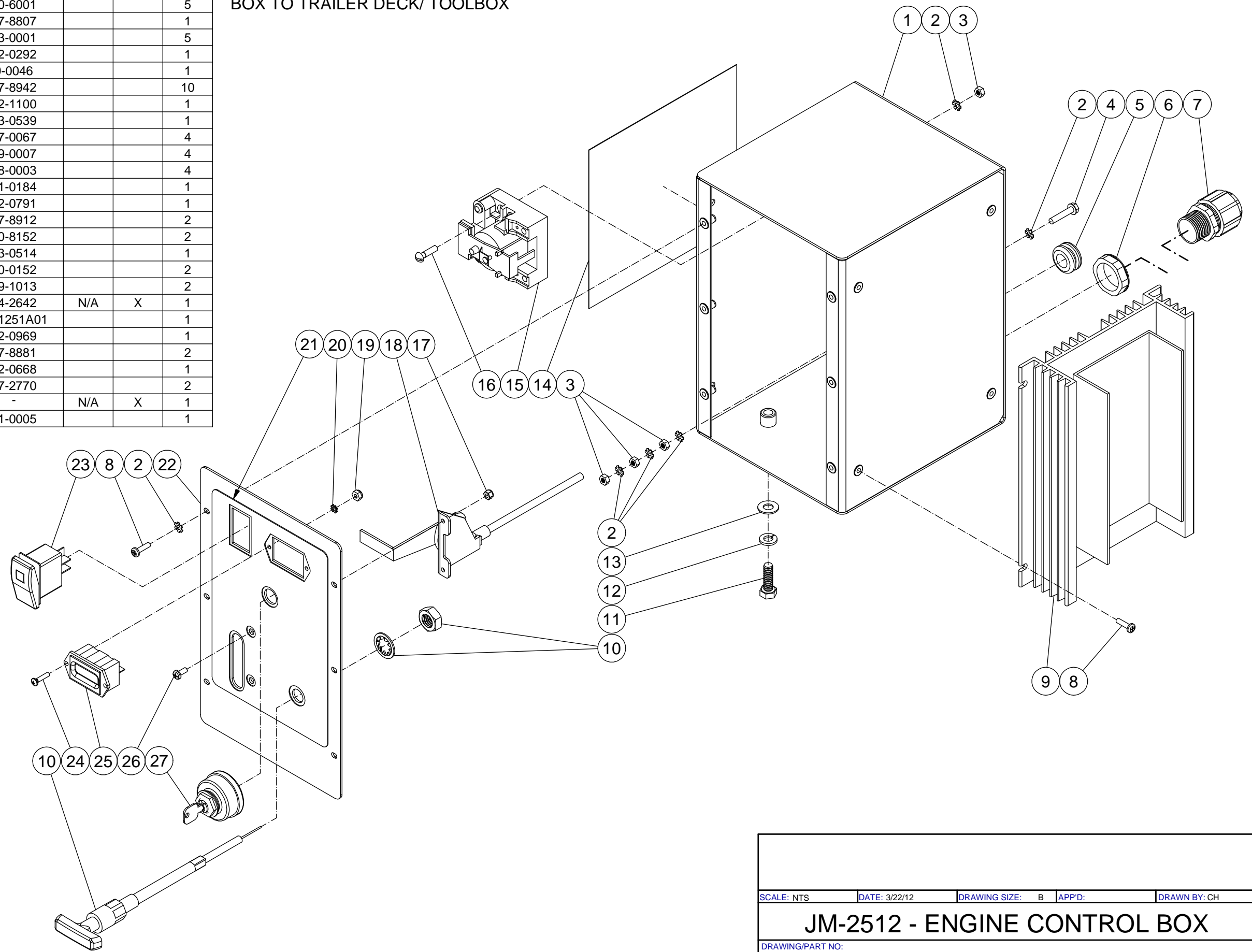

SCALE: NTS	DATE: 3/22/12	DRAWING SIZE: B	APPD:	DRAWN BY: CH
JM-2512 - ENGINE CONTROL BOX				
DRAWING/PART NO: JM-2512 - ENGINE CONTROL BOX				

M:\Drawings\PRIVATE LABEL\GENERAL PIPE CLEANERS\JM-2512-0GH\JM-2512 - TOOLBOX ASSY.iam

NOTE: BOLTS (10), WASHERS (11), AND LOCKNUTS (12) ARE USED TO SECURE TOOLBOX TO TRAILER DECK

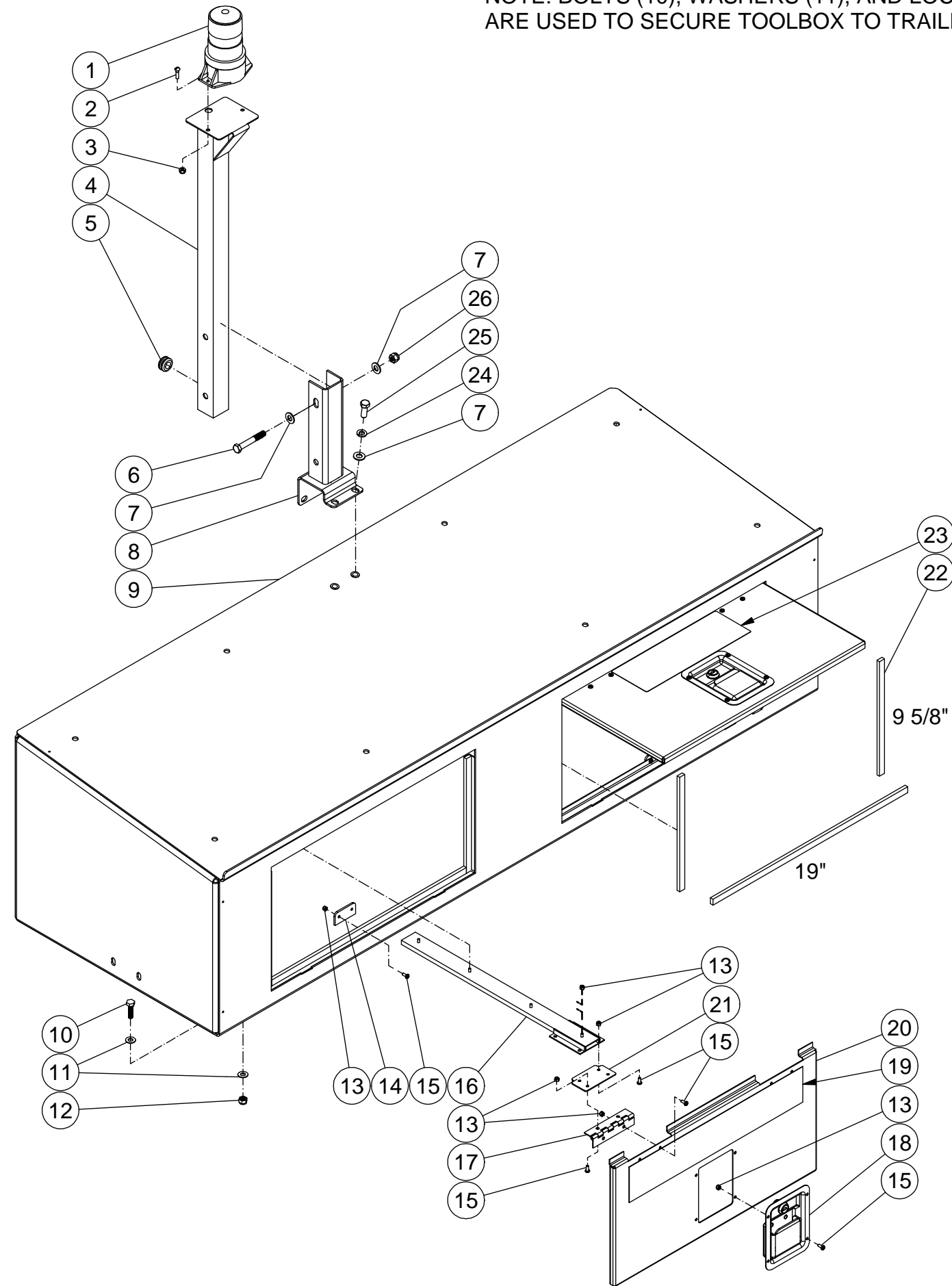

ITEM	DESCRIPTION	PART #	P/L	R/Q	QTY
1	STROBE LIGHT	32-1085			1
2	PRHMS - #10-32 X 3/4 ZINC	27-8912			2
3	HEX NYLON LOCKNUT-ZINC #10-32	30-0136			2
4	LIGHT POST	20-1243A64			1
5	GROMMET 1/2 X 3/4 X 1/8	33-0001			3
6	BOLT - HHCS - ZI GR5 3/8-16 x 2-1/2"	27-0123			2
7	WASHER - ZI SAE 3/8"	28-0004			8
8	LIGHT POST MOUNT	20-1242A64			1
9	TOOLBOX - JETTER TRAILER	20-1262A64			1
10	BOLT - HHCS - ZI GR5 5/16-18 X 1-1/4"	27-0068			6
11	WASHER-ZI SAE TYPE A 5/16"	28-0003			12
12	HEX NYLON LOCKNUT-ZINC 5/16-18	30-0157			6
13	HEX NYLON LOCKNUT - SS M4 - .7P	30-8152			52
14	STRIKER PLATE	20-1245A01			2
15	PPHMS M4-0.7X16MM - SS	27-2770			36
16	SLIDE - LINEAR MOTION	33-0515			4
17	HINGE - 1 1/2" X 4" SS	43-0105			4
18	PADDLE LATCH - SS/ LOCKING	33-0516			2
19	DECAL - JM-2512 TOOLBOX DOOR	34-2639	N/A	X	1
20	DOOR	20-1244A64			2
21	DOOR HINGE MOUNT	20-1246A01			4
22	WEATHERSTRIP - ADHESIVE BACK	26-0378		76.5"	1
23	DECAL - WARNING/OPERATION SEWER JETTER	34-2624	N/A	X	1
24	LOCKWASHER - ZI MED 3/8	29-0008			4
25	BOLT - HHCS 3/8-16 X 1	27-0117			4
26	HEX NYLON LOCKNUT - ZI 3/8-16	30-0159			2
27	CONDUIT 3/4" BLACK	32-0486		???	1
28	CONDUIT 90 ELBOW 3/4"	32-0487			1
29	LOCKNUT 1/2" ELECTRICAL	32-0108			1
30	STRAIN RELIEF	32-0437			1
31	CONDUIT FITTING 1" BLACK	32-0996			1
32	CONDUIT FLEX 1" BLACK	32-0908		68"	1

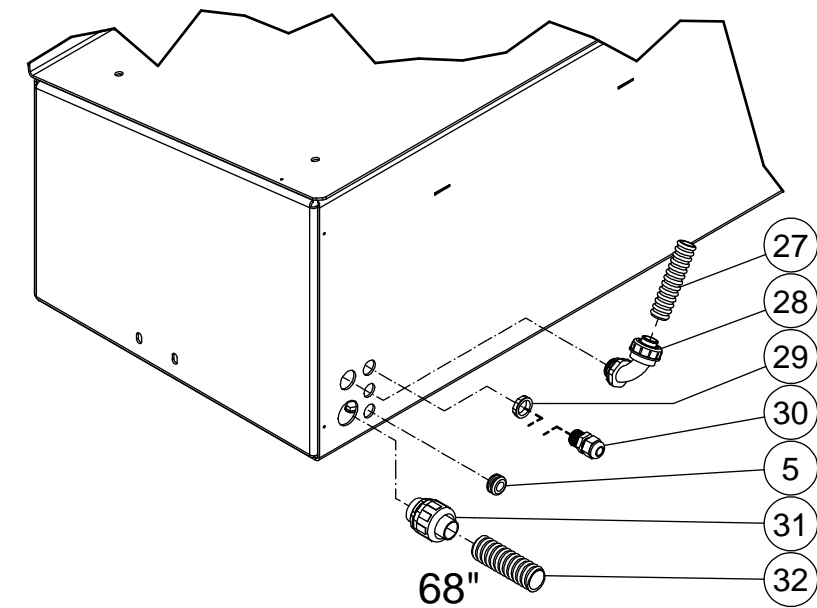

SCALE: NTS	DATE: 1/5/12	DRAWING SIZE: B	APPD:	DRAWN BY: CH
JM-2512-0GH - TOOLBOX ASSY				
DRAWING/PART NO: JM-2512 - TOOLBOX ASSY				

M:\Drawings\PRIVATE LABEL\GENERAL PIPE CLEANERS\JM-2512-0GHJM-2512 - HOSE REELS ASSY .iam

NOTE: QTY (8) BOLTS (#3), (16) WASHERS (#2), AND (8) LOCKNUTS (#1) ARE USED TO SECURE HOSE REELS TO TOOLBOX (20-1262A64)

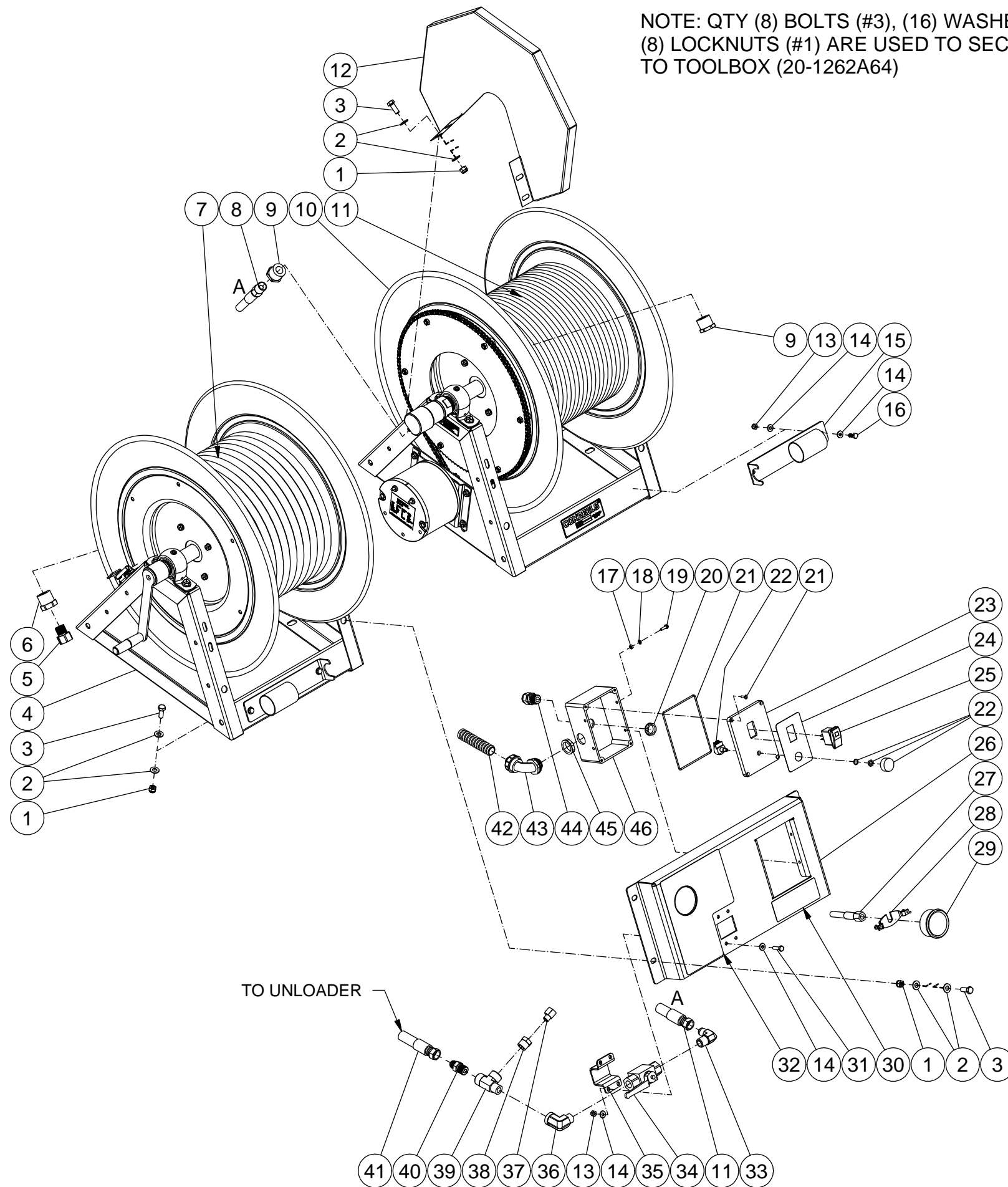

ITEM	DESCRIPTION	PART #	P/L	R/Q	QTY
1	HEX NYLON LOCKNUT - ZI 3/8-16	30-0159			14
2	WASHER - ZI SAE 3/8"	28-0004			28
3	BOLT - HHCS 3/8-16 X 1	27-0117			14
4	HOSE REEL - HAND CRANK	50-0193			1
5	SWIVEL - 1/2M X 3/4F GARDEN HOSE	23-0095			1
6	REDUCER - BRASS - 1"M x 1/2"F	23-0226			1
7	HOSE - 3/4" GARDEN 150'	15-0316			1
8	HOSE 1/2" X 24"	15-0263			1
9	REDUCER - 1"M X 1/2"F	24-0303			2
10	HOSE REEL - ELECTRIC	50-0194			1
11	HP HOSE - 1/2" X 400'	15-0322			1
12	GEAR GUARD	50-0197A18			1
13	HEX NYLON LOCKNUT-ZINC 1/4-20	30-0155			8
14	WASHER-ZI SAE TYPE A 1/4"	28-0002			16
15	HOSE RETAINER	20-1240A64			2
16	HHCS-ZI GR5 1/4-20 X 3/4"	27-0015			4
17	HEX NUT - M5 X 0.8	30-6001			4
18	EXTERNAL TOOTH LOCKWASHER	28-1009			4
19	HHCS - GR8.8 M5-0.8P X 16MM BLACK	27-9526			4
20	LOCKNUT 1/2" ELECTRICAL	32-0108			1
21	HARDWARE KIT	70-0197			1
22	VARIABLE SPEED CONTROL	32-1100			1
23	CONTROL BOX LID	20-1256A01			1
24	DECAL - VARIABLE SPEED CONTROLS	34-2650	N/A	X	1
25	SWITCH - ROCKER W/ LAMP 12V	32-0969			1
26	HOSE REEL CONTROL PANEL	20-1241A64			1
27	HP HOSE - 1/4" ID X 1/4MS X 1/4F X 13.25"	15-0309			1
28	U-CLAMP - GAUGE MOUNT	13-0211			1
29	GAUGE - 0-5000PSI 2 1/2"DIA BACK MOUNT	22-0465			1
30	DECAL - GENERAL JET-SET TYPHOON	34-2651	N/A	X	1
31	HHCS - ZI GR5 1/4-20X1	27-0016			4
32	DECAL - HOSE REEL CONTROL PANEL	34-2644	N/A	X	1
33	ELBOW 1/2M X #8JIC MALE	24-0074			1
34	BALL VALVE - 1/2" FNPT 7350PSI	22-0463			1
35	BALL VALVE HOLDER	20-1254A01			1
36	ELBOW 1/2MPX1/2FP 90 STEEL FORGE	24-0006			1
37	ELBOW 1/4"FPX1/4MPT 90 BRASS	23-0014			1
38	REDUCER 1/2MP X 1/4 FP HEX - STEEL	24-0053			1
39	STREET TEE-1/2NPT STEEL FORGED	24-0242			1
40	NIPPLE 1/2MP X #8JIC HEX	24-0054			1
41	HOSE 1/2" X 9'	15-0314			1
42	CONDUIT 3/4" BLACK	32-0486		???	1
43	CONDUIT 90 ELBOW 3/4"	32-0487			1
44	STRAIN RELIEF	32-0437			1
45	LOCKNUT ELECT 3/4"	32-0292			1
46	CONTROL BOX	20-1255A01			1

SCALE: NTS	DATE: 1/5/12	DRAWING SIZE: B	APPD:	DRAWN BY: CH
JM-2512 - HOSE REELS ASSY				
DRAWING/PART NO: JM-2512 - HOSE REELS ASSY				

NOTE: PLACE TRAILER SPEC STICKERS & SILVER STICKER ON DRIVER'S SIDE OF TONGUE; BETWEEN FRONT OF DECK AND TONGUE BRACES

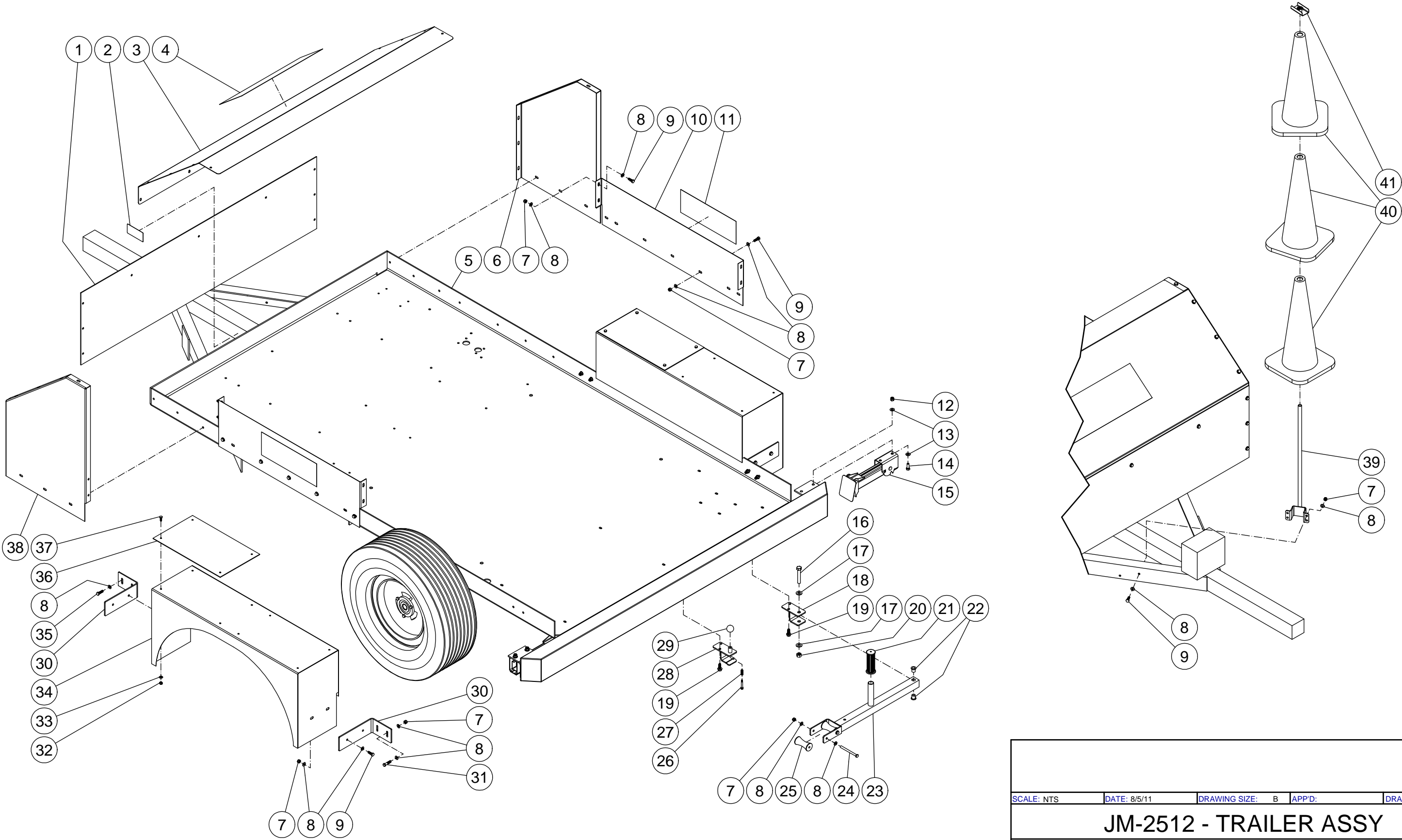

M:\Drawings\PRIVATE LABEL\GENERAL PIPE CLEANERS\JM-2512-0GHJM-2512 - TRAILER ASSY.iam

SCALE: NTS	DATE: 8/5/11	DRAWING SIZE: B	APPD:	DRAWN BY: CH
JM-2512 - TRAILER ASSY				
DRAWING/PART NO: JM-2512 - TRAILER ASSY				

M:\Drawings\PRIVATE LABEL\GENERAL PIPE CLEANERS\JM-2512-0GH\JM-2512 - TRAILER ASSY.iam

ITEM	DESCRIPTION	PART #	P/L	R/Q	QTY
1	FRONT COVER - TRAILER	56-0071			1
2	DECAL - SILVER STICKER	34-0075	N/A		1
3	FRONT PANEL - TRAILER	20-1236A64		X	1
4	DECAL - JM-2512 FRONT PANEL	34-2634		X	1
5	SINGLE AXLE W/ELECTRIC BRAKES	61-0013			1
6	RIGHT SUPPORT PANEL	20-1238A64			1
7	HEX NYLON LOCKNUT-ZINC 5/16-18	30-0157			55
8	WASHER-ZI SAE TYPE A 5/16"	28-0003			110
9	BOLT - HHCS - ZI GR5 5/16-18 x 1"	27-0067			45
10	MIDDLE PANEL - TRAILER	20-1239A64			2
11	DECAL - JM-2512 SIDE PANEL	34-2633		X	2
12	HEX NYLON LOCKNUT - ZI 3/8-16	30-0159			4
13	WASHER - ZI SAE 3/8"	28-0004			8
14	BOLT - HHCS 3/8-16 X 1	27-0117			4
15	STABILIZER ARM	61-1035			2
16	HHCS-ZI GR5 1/2-13 X 3	27-0227			1
17	WASHER - ZI SAE TYPE A 1/2	28-0006			2
18	HOSE GUIDE MOUNT	20-1248A01			1
19	HWHCS - ZI 3/8-16 X 1	27-9530			4
20	HEX NYLON LOCKNUT-ZINC 1/2-13	30-0163			1
21	HANDLE GRIP	7-0167			1
22	SLEAVE BEARING - 1/2" ID	33-0518			2
23	HOSE GUIDE	20-1247A01			1
24	HHCS-ZI GR5 5/16-18 x 4"	27-0079			2
25	HOSE GUIDE ROLLER	51-0043			2
26	SHOULDER SCREW-#10-24 X 1/4" X 1.625" LONG	27-0895			1
27	SPRING 1" LONG X 5/16" O.D. ZINC PLATED	49-0165			1
28	HOSE GUIDE CATCH	20-1249A01			1
29	KNOB-1.25" DIA. X 10"-24 STEEL INSERT	7-0223			1
30	FENDER BRACKET	20-1064A01			4
31	HHCS-ZI GR5 5/16-18 X 1-1/2	27-0069			4
32	HEX NYLON LOCKNUT-ZINC 1/4-20	30-0155			8
33	WASHER-ZI SAE TYPE A 1/4"	28-0002			8
34	TRAILER FENDER	20-1155A18			2
35	BOLT - HHCS - ZI GR5 5/16-18 X 1-1/4"	27-0068			4
36	FENDER STEP	56-0066			2
37	HHCS-ZI GR5 1/4-20 X 3/4"	27-0015			8
38	LEFT SUPPORT PANEL	20-1237A64			1
39	SAFETY CONE HOLDER	20-1257A01			1
40	SAFETY CONE	61-1034			3
41	HANDLE NUT - 5/8"	20-1258A01			1

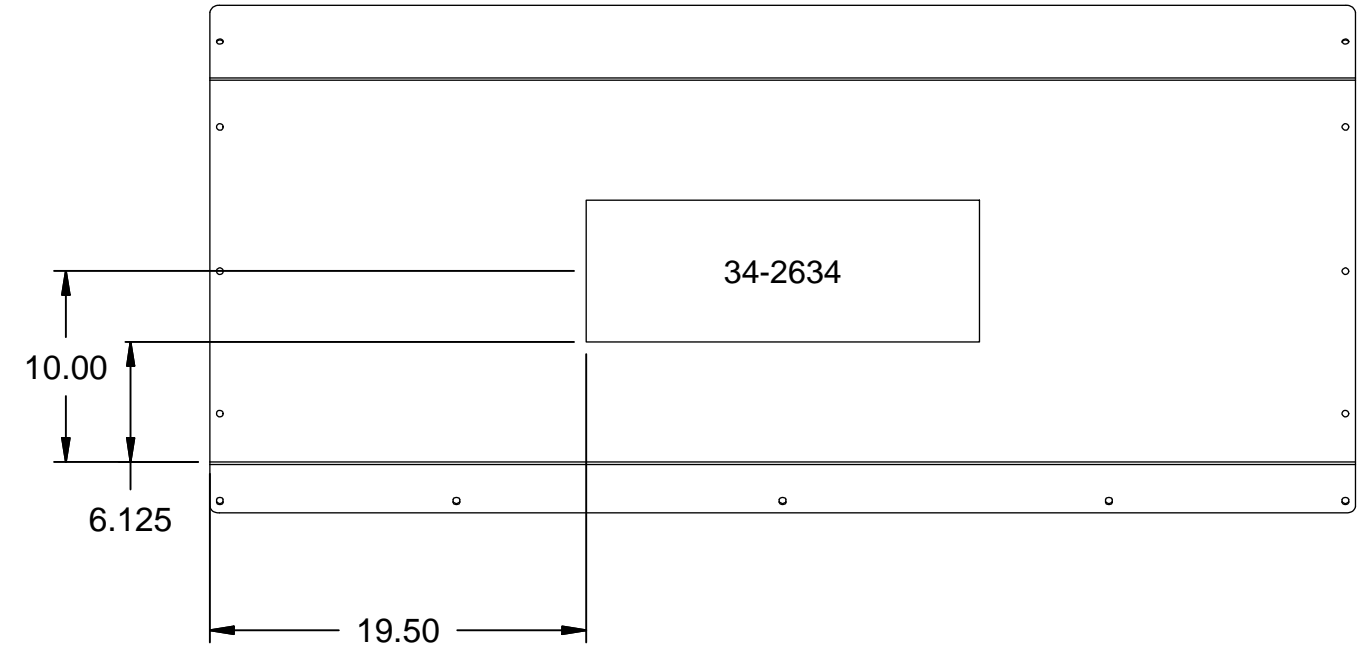

SCALE: NTS	DATE: 8/5/11	DRAWING SIZE: B	APPD:	DRAWN BY: CH
JM-2512 - TRAILER ASSY				
DRAWING/PART NO: JM-2512 - TRAILER ASSY				

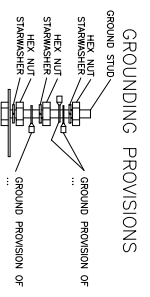
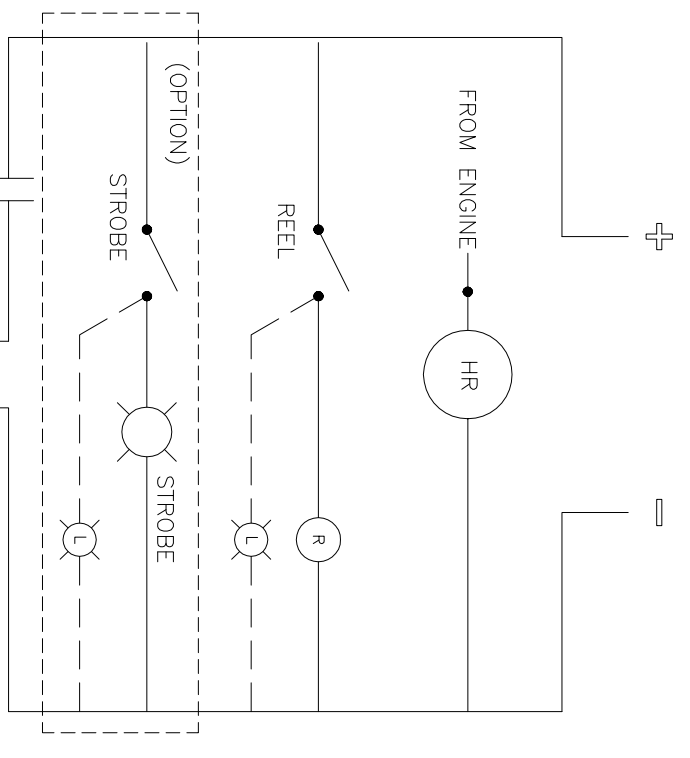
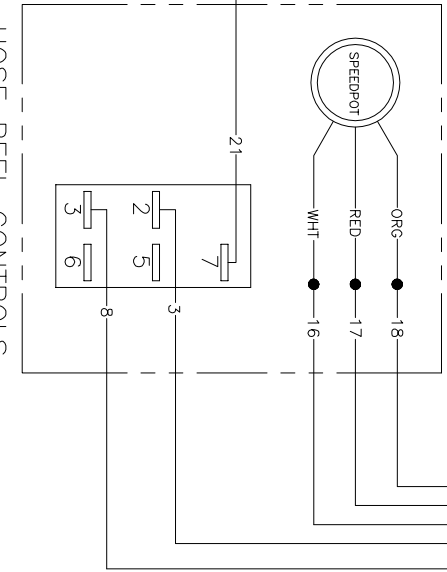
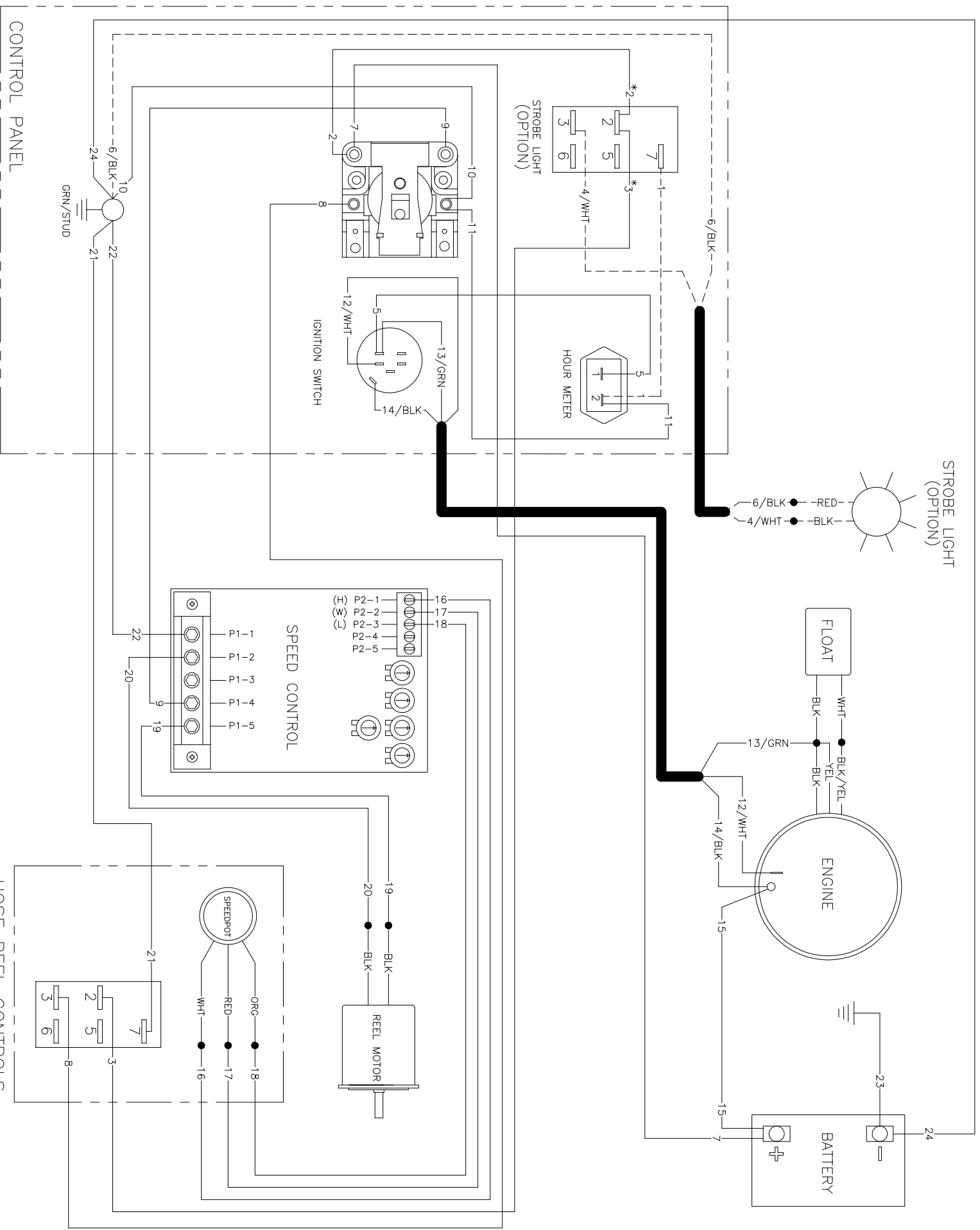

M:\Drawings\Part Numbers\61\61-0013.iam

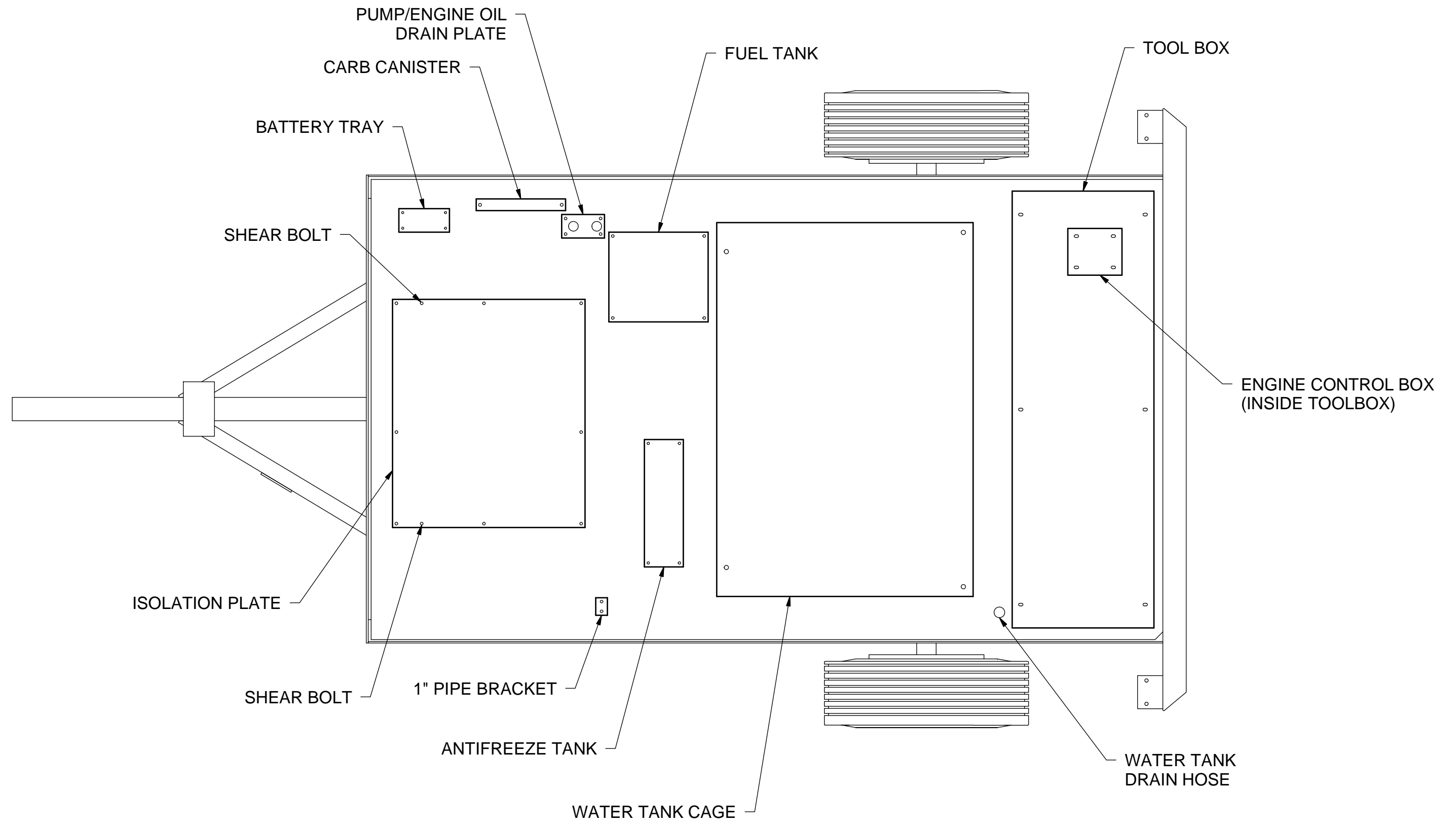

SCALE: NTS	DATE: 3/22/12	DRAWING SIZE: B	APPD:	DRAWN BY: CH
JM-2512-0GH TRAILER HOLE LOCATIONS				
DRAWING/PART NO: 61-0013				

ITEM	DESCRIPTION	VENDOR #	Mi-T-M #	P/L	QTY
1	VALVE CAP	66130041	46-1222		6
2	BACK UP RING - O.D. 29 X I.D. 24.5 X 1.5mm	90516500	25-0592		6
3	O-RING .937 x .103	90385700	25-0139		6
4	VALVE ASSEMBLY	36722701	-	N/A	6
5	MANIFOLD - BRASS - 24mm	66120241	46-1508		1
6	O-RING 7/16 X 9/16	90358500	25-0014		4
7	PLUG- 1/4" X 13	98204300	39-0222		3
8	LOCKWASHER M10 SERR CURVE	96710400	29-0155		8
9	BOLT - HHCS M10-1.5P x 90mm	99380100	27-9595		8
10	GASKET - ALUMINUM 3/4"	96770000	28-1051		1
11	PLUG- 3/4" X 16	98226500	39-0221		1
12	WASHER - ALUM - O.D. 22 X I.D. 17.2 X 1.5mm	12401900	28-1002		1
13	PLUG/HEX - BRASS 3/8-19 BSPP-F	98210000	39-0018		2
14	HIGH PRESSURE SEAL ASSEMBLY	90274100	-	N/A	3
15	HIGH PRESSURE INTERMEDIATE RING - 24mm	66216470	-	N/A	3
16	LOW PRESSURE SEAL ASSEMBLY	90273800	-	N/A	3
17	O-RING - 34.65 X 1.78mm	90361600	25-0015		3
18	LOW PRESSURE SEAL RETAINER	66080470	-	N/A	3
19	OIL SEAL - 22 X 32 X 5.5	90162500	26-0047		3
20	BUSHING/BEARING - 22 X 25 X 30mm	90912600	9-0029		3
21	O-RING 9/16 X 3/4	90383300	25-0052		1
22	OIL SEAL - 30 X 55 X 7	90164800	26-0049		1
23	SHHCS - M8-1.25P X 16MM	99303900	27-8431		4
24	COVER/CRANKCASE OPEN	66150022	46-1217		1
25	O-RING - 67.95 X 2.62mm	701147	25-0590		2
26	BEARING - ROLLER - SKF - 2206EC	91838000	48-0085		2
27	KEY - 8 X 7 X 35mm	91489200	46-0602		1
28	CRANKSHAFT 21MM STROKE	66020435	46-1210		1
29	PLUG/HEX - BRASS G1/4	98204100	39-0017		1
30	SIGHT GLASS	63210051	46-1163		1
31	O-RING 1-1/16 X 1-5/16	90405100	25-0059		1
32	BOLT - HSHCS M6-1.0P X 20mm	99188400	27-8812		4
33	COVER/CRANKCASE	66160000	46-1212		1
34	O-RING - 133.02 X 2.62mm	90392200	25-0339		1
35	SHHCS - M8 - 1.25P x 35mm	99309900	27-8435		6
36	LOCKWASHER - M8	96701400	29-1014		6
37	CONNECTING ROD - ID 40 X W 29.70 MM	66030001	46-1211		3
38	PIN/CONNECTING ROD - Ø14 X 36mm	97740500	43-0118		3
39	PISTON ROD	66050064	46-1213		3
40	SLINGER WASHER OD 28 X ID 10 X .5MM	96710100	46-1214		3
41	PLUNGER - CERAMIC - 24mm	66040409	46-1509		3
42	O-RING .426 X .070	701013	25-0310		3
43	BOLT/PISTON - M7 X 1.0P X 14MM	66219566	46-1216		3
44	OIL DIP STICK	98210600	46-0144		1
45	CRANKCASE	66010022	46-1209		1
46	COVER/CRANKCASE SIGHTGLASS	66150122	46-1208		1
47	O-RING 55.56 X 3.53MM	90409700	25-0060		1
48	OIL LEVEL INDICATOR/SPACER	44211801	46-0574		1
49	SIGHTGLASS COVER	66150274	46-1207		1
50	SHHCS - ZI GR8.8 M8-1.25P x 25mm	99306900	27-8433		4

Q/C INSPECTION

1) VISUAL INSPECTION
A) FREIGHT DAMAGE
B) OIL LEAKS: ANY SIGN OF OIL IN BOX
C) OIL LEVEL: 1/2 SIGHT GLASS
D) RIGHT-HAND (RH) PUMP

2) CHECK THESE TORQUES:
A) HEAD BOLTS - 33.2 FT-LBS
B) VALVE CAPS - 95.9 FT-LBS
C) PLUNGER RETAINER - 14.8 FT-LBS
D) CONNECTING ROD SCREWS - 14.8 FT-LBS

3) ACL 6.5 LEVEL I

Mi-T-M #	VENDOR #	BORE	STROKE	MAX RPM	MAX GPM	MAX PSI	OIL	INLET	OUTLET	SHAFT DIA.
3-0372	TSF2421	24mm	21mm	1750	12.0	2500	40.6 oz	3/4"-14 BSP-F	3/8"-19 BSP-F	24mm

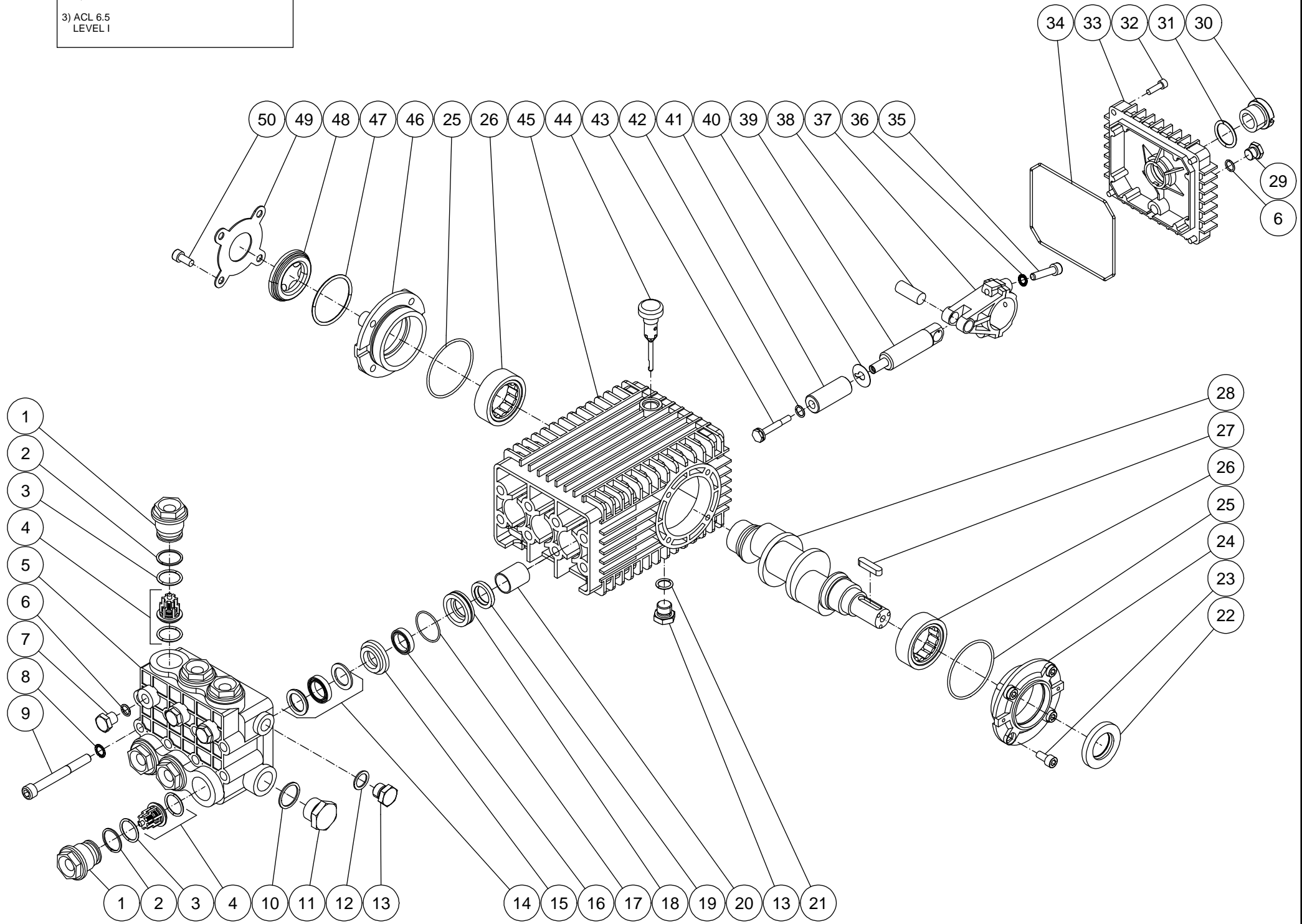

TORQUE SPECS.	
POSITION	FT-LBS
1	95.9
7	29.5
9	33.2
11	51.6
13	29.5
23	14.8
29	14.8
32	7.4
35	14.8
43	14.8
50	14.8

** USE LOC-TITE 542

GENERAL KIT#	K02	K169	K181	K182
Mi-T-M KIT#	70-0432	70-0439	70-0607	70-0608
DESCRIPTION	OIL SEAL KIT	VALVE KIT	LOW/HIGH PRESSURE SEALS	PACKING KIT
ITEMS	19	4	14, 16	14-18
# OF ASSEMBLIES	3	6	3	1
# OF CYLINDERS	3	3	3	1



Mi-T-M CORPORATION • PEOSTA, IA 52068

SCALE: NTS	DATE: 8/29/12	DRAWING SIZE: B	APPD:	DRAWN BY: RSW
PUMP - TSF2421				
DRAWING/PART NO: 3-0372				

M:\Drawings\Part Numbers\03-0372.iam