

Speedroter 92[®]

Operating Instructions

For 3" through 10"
(75mm—250mm)



Your Speedroter 92 is designed to give you years of trouble-free, profitable service. However, no machine is better than its operator.

Read, understand and follow all safety warnings and instructions provided with the product. Failure to follow the warnings and instructions may result in electric shock and/or serious injury. Save all warnings and instructions for future reference.

SAVE THESE INSTRUCTIONS!

General
PIPE CLEANERS



WARNING

Read and understand operator's manual before using this machine. Failure to follow operating instructions could result in death or serious injury.

WARNING! Read and understand all instructions. Failure to follow all instructions listed below may result in electric shock, fire and/or serious personal injury. Replacement manuals are available upon request at no charge, or may be downloaded from our website, www.drainbrain.com. Instructional videos are available for download on our website, and may be ordered. If you have any questions or problems, please call General's customer service department at 412-771-6300.

SAVE THESE INSTRUCTIONS!

These instructions are intended to familiarize all personnel with the safe operation and maintenance procedures for the Speedrooter 92.

SAFETY SYMBOLS



This is the safety alert symbol. It is used to alert you to potential personal injury hazards. Obey all safety messages that follow this symbol to avoid possible injury or death.

DANGER

DANGER indicates a hazard with a high level of risk which, if not avoided, will result in death or serious injury.

WARNING

WARNING indicates a hazard with a medium level of risk which, if not avoided, could result in death or serious injury.

CAUTION

CAUTION indicates a hazard with a low level of risk which, if not avoided, will result in minor or moderate injury.

WARNING



Electric shock resulting in death can occur if you plug this machine into an improperly wired outlet. If the ground wire is electrified, you can be electrocuted by just touching the machine, even when the power switch is off. A ground fault circuit interrupter will not protect you in this situation. Use a UL approved tester to determine if the outlet is safe.



Do not operate power tools in explosive atmospheres, such as in the presence of flammable liquids, gases, or dust. Power tools create sparks which may ignite the dust or fumes.



Only wear leather gloves. Never use any other type of glove, such as cloth, rubber, or coated gloves. Never grasp a rotating cable with a rag. These items could become wrapped around the cable and cause serious injury.



Always wear safety glasses and rubber soled, non-slip shoes. Use of this safety equipment may prevent serious injury.

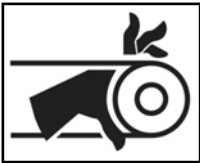

Never operate machine with belt guard removed. Fingers can get caught between belt and pulley.



Do not overstress cables. Overstressing cables may cause twisting, kinking, or breaking of the cable and may result in serious injury.

GENERAL SAFETY RULES

WARNING

Read and understand all instructions. Failure to follow all instructions listed below may result in electric shock, fire, and/or serious injury.

SAVE THESE INSTRUCTIONS!

Work Area

1. **Keep work area clean and well lit.** Cluttered benches and dark areas invite accidents.
2. **Do not operate power tools in explosive atmospheres, such as in the presence of flammable liquids, gases, or dust.** Power tools create sparks which may ignite the dust or fumes.
3. **Keep bystanders, children, and visitors away while operating a power tool.** Distractions can cause you to lose control.

Electrical Safety

1. **Grounded tools must be plugged into an outlet, properly installed and grounded in accordance with all codes and ordinances. Never remove the grounding prong or modify the plug in any way. Do not use any adapter plugs. Check with a qualified electrician if you are in doubt as to whether the outlet is properly grounded.** If the tool should electrically malfunction or break down, grounding provides a low resistance path to carry electricity away from the user.
2. **Avoid body contact with grounded surfaces such as pipes, radiators, ranges and refrigerators.** There is an increased risk of electric shock if your body is grounded.
3. **Do not expose power tools to rain or wet conditions.** Water entering a power tool will increase the risk of electric shock.
4. **Do not abuse the cord.** Never use the cord to carry the tools or pull the plug from an outlet. Keep cord away from heat, oil, sharp edges or moving parts. Replace damaged cords immediately. Damaged cords increase the risk of electric shock.
5. **When operating a power tool outside use an outdoor extension cord marked "W-A" or "W".** These cords are rated for outdoor use and reduce the risk of electric shock.
6. **Test the Ground Fault Circuit Interrupter (GFCI) provided with the power cord to insure it is operating correctly before operating machine.** Machine must have a properly functioning ground fault circuit interrupter on the power cord. GFCI reduces the risk of electric shock.
7. **Extension cords are not recommended unless they are plugged into a Ground Fault Circuit Interrupter (GFCI) found in circuit boxes or outlet receptacles.** The GFCI on the machine power cord will not prevent electric shock from the extension cords.
8. **Only use proper three-wire extension cords in good condition which have three-prong grounding plugs and three-pole receptacles which accept the tool's plug. Use of damaged, inferior, or other extension cords will not ground the tool.** Increases the risk of electric shock and bodily injury or death.
9. **Keep all electric connections dry and off the ground.** Reduces the risk of electric shock.
10. **DO NOT touch plugs or tools with wet hands.** Reduces the risk of electric shock.

Personal Safety

1. **Stay alert, watch what you are doing and use common sense when operating a power tool. Do not use tool while tired or under the influence of drugs, alcohol, or medication.** A moment of inattention while operating power tools may result in serious personal injury.
2. **Dress properly. Do not wear loose clothing or jewelry. Contain long hair. Keep your hair, clothing, and gloves away from moving parts.** Loose clothes, jewelry, or long hair can be caught in moving parts.
3. **Avoid accidental starting. Be sure switch is off before plugging in.** Carrying tools with your finger on the switch or plugging in tools that have the switch on invites accidents.
4. **Remove adjusting keys or wrenches before turning the tool on.** A wrench or key that is left attached to a rotating part of the tool may result in personal injury.
5. **Do not overreach. Keep proper footing and balance at all times.** Proper footing and balance enables better control of the tool in unexpected situations.
6. **Use safety equipment. Always wear eye protection.** Dust mask, non-skid safety shoes, hard hat, or hearing protection must be used for appropriate conditions.

Tool Use and Care

1. **Use clamps or other practical way to secure and support the workpiece to a stable platform.** Holding the work by hand or against your body is unstable and may lead to loss of control.
2. **Do not force tool. Use the correct tool for your application.** The correct tool will do the job better and safer at the rate for which it is designed.
3. **Do not use tool if switch does not turn it on or off.** Any tool that cannot be controlled with the switch is dangerous and must be repaired.
4. **Disconnect the plug from the power source before making any adjustments, changing accessories, or storing the tool.** Such preventative safety measures reduce the risk of starting the tool accidentally.
5. **Store idle tools out of reach of children and other untrained persons.** Tools are dangerous in the hands of untrained users.
6. **Maintain tools with care. Keep cutting tools sharp and clean.** Properly maintained tools, with sharp cutting edges are less likely to bind and are easier to control.
7. **Check for misalignment or binding of moving parts, breakage of parts, and any other condition that may affect the tool's operation. If damaged, have the tool serviced before using.** Many accidents are caused by poorly maintained tools.
8. **Only use accessories that are recommended by the manufacturer for your model.** Accessories that may be suitable for one tool may become hazardous when used on another tool.

Service

1. **Tool service must be performed only by qualified repair personnel.** Service or maintenance performed by unqualified repair personnel could result in a risk of injury.
2. **When servicing a tool, use only identical replacement parts. Follow instructions in the Maintenance section of this manual.** Use of unauthorized parts or failure to follow Maintenance Instructions may create a risk of electric shock or injury.

SPECIFIC SAFETY RULES



This is the safety alert symbol. It is used to alert you to potential personal injury hazards. Obey all safety messages that follow this symbol to avoid possible injury or death.



Electric shock resulting in death can occur if you plug this machine into an improperly wired outlet. If the ground wire is electrified, you can be electrocuted by just touching the machine, even when the power switch is off. A ground fault circuit interrupter will not protect you in this situation. Use a UL approved tester to determine if the outlet is safe.



Do not overstress cables. Overstressing cables may cause twisting, kinking, or breaking of the cable and may result in serious injury.

1. **Only wear leather gloves.** Never use any other type of glove, such as cloth, rubber, or coated gloves. Never grasp a rotating cable with a rag. These items could become wrapped around the cable and cause serious injury.
2. **Never operate machine with belt guard removed.** Fingers can get caught between belt and pulley.
3. **Do not overstress cables.** Keep leather-gloved hand on the guide tube for control when machine is running. Overstressing cables because of an obstruction may cause twisting, kinking, or breaking of the cable and may result in serious injury.
4. **Place the machine at a distance not greater than two feet (.6m) from the opening.** Greater distances can result in cable twisting or kinking.
5. **Machine is designed for ONE-PERSON operation.** Operator must control foot switch and cable.
6. **Do not operate machine in reverse (REV).** Operating machine in reverse can result in cable damage and is used only to back cutting tool out of an obstruction.
7. **Keep hands away from rotating drum.** Do not reach into drum unless machine is unplugged. Hand may be caught in the moving parts resulting in serious injury.
8. **Be careful when cleaning drains where cleaning chemicals have been used.** Avoid direct contact with skin and eyes. Drain cleaning chemicals can cause serious burns as well as damage the cable.
9. **Do not operate machine if operator or machine is standing in water.** Will increase risk of electrical shock.
10. **Wear safety glasses and rubber soled, non-slip shoes.** Use of this safety equipment may prevent serious injury.
11. **Before starting each job, check that the cable in the drum is not broken or kinked, by pulling the cable out and checking for wear or breakage.** Always replace worn out (kinked or broken) cables with genuine GENERAL replacement cables.
12. **Only use this tool in the application for which it was designed. Follow the instructions on the proper use of the machine.** Other uses or modifying the drain cleaner for other applications may increase risk of injury.

Ground Fault Circuit Interrupter (GFCI)

Your machine is equipped with a ground fault circuit interrupter, which

protects you against shock if a short circuit should occur. Check that receptacle is properly grounded. Test the GFCI before each use.

1. Plug into 120-volt receptacle.
2. Push test button. Indicator light will go out and power to machine should cut off.
3. If light does not go out when test button is pushed, **DO NOT USE THE MACHINE** until proper repairs can be made.
4. To restore power after test, push reset button. With the reset button depressed, if the machine doesn't start, stops while running, or if the operator experiences a mild shock, **DO NOT USE THE MACHINE!** Tag the machine out of service and take it to a motor repair center or return it to the factory for repairs.



THE SECTION OF CORD BETWEEN THE WALL PLUG AND THE GFCI IS NOT IN THE PROTECTED CIRCUIT.

FEATURES

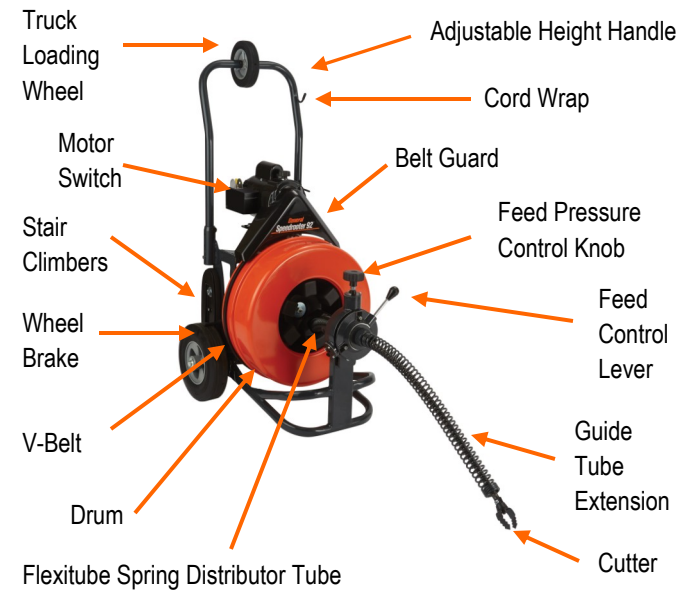











NOTE: Do not operate machine if warning labels on the switch box and power cord are missing or illegible.

Cable Application Chart (Table 1)

Cable Size	Pipe Size	Typical Applications
3/4" (Large Drum)	4" to 10"	Large Drains, Long Runs, Roots
5/8" (Large Drum)	3" to 6"	Floor Drains, Roots
9/16" (Small Drum)	2" to 4"	Stacks & Small Drains (No Roots)

Cutter Application Chart (Table 2)

Cutter	Cat. #	Typical Applications
Cutters for 5/8" and 3/4" Cables		
Spear Head 	SHD	Starting Drill—gets water flowing.
2" U-Cutter 	2UC	For Cutting and Scraping
3" & 4" Side Cutter Blades 	3SCB & 4SCB	For Cutting—Scraping walls of pipe.
3" Heavy Duty Saw Blade 	3HDB	For Cutting Roots
4" Rotary Saw Blade 	4RSB	For Cutting Roots
Large Retrieving Tool 	RTR-2	For removing loose objects or broken cables.
26" Flexible Leader 	LE-3	Helps cable get through tight traps and bends.
Cutters for 9/16" Cables		
Arrow Head 	AH	Starting Tool, ideal for cutting and scraping.
1-1/2" U-Cutter 	1-1/2UC	Finishing tool, works well in grease stoppages.
Small Retrieving Tool 	RTR-1	To remove or retrieve loose objects.
13" Flexible Leader 	LE-1	Tool for negotiating around difficult bends.

Note: There are no fixed rules for what cutter to use. If one tool doesn't take care of a stoppage, simply try another.

OPERATION

SET-UP



1. Be sure the motor switch is in the **off** position.
2. Place machine at a distance not greater than two feet (.6 m) from the drain opening. Be sure the Speedrooter Guide Tube (S92-GT) is in place. If you can't get the machine this close to the drain opening, run the cable through the optional Guide Tube Extension (GTE) or a metal guide tube to prevent cable whipping.

3. Position the air foot pedal for easy accessibility. The machine is designed for one-person operation. Be sure you can quickly remove your foot from the pedal in an emergency.



4. Lock the wheels by lifting the brake handle located next to the left wheel and pressing it into the clip.
5. Make sure the Power Cable Feed is set to match the cable size you have selected. If you're using 3/4" or 5/8" cables, the feed should be assembled with the raised side of the lower two caps outward. If you are using 9/16" cables, the feed should be assembled with the raised side of the caps inward.
6. Select the proper cutting tool (See Cutter Application Chart—Table 2). A good tool to start with is the Spearhead or 2" U-Cutter. If you are having difficulty getting around a P-Trap or close bend, try the flexible leader. After the line has been opened, follow with larger blades, which scrape the inside edges of the pipe, assuring a real cleaning job.
7. Insert the cutter into the female connector at the end of the cable and tighten the connecting screw and lock washer **firmly** in place.

OPERATION

1. Place the Guide Tube, with cable and cutter protruding from the end, securely into the drain opening.
2. Tighten the knob at top of the Power Cable Feed so that the feed roller presses against the cable. Be sure not to over tighten since this could cause excess cable wear.
3. The feed lever controls the feeding rate and direction of the cable. Move the lever down to feed cable out of drum. The further the lever is moved downward, the faster the cable will feed out. Move lever up to retract cable into drum. When the lever is in the middle (neutral) position, cable will spin in place.

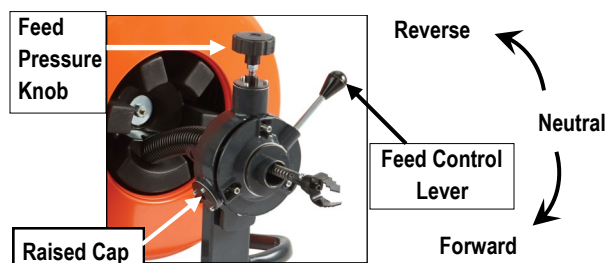

4. Move the motor switch to the **forward** position.
5. With a gloved hand on the Guide Tube, depress the air foot pedal to start machine. Feed the cable into the line. Adjust the feeding rate to the resistance met. **Do not force the cable** - let the cutter do the work. The job won't go any faster and you could damage the cable.

6. If the cable starts to buckle or twist, release pressure on the foot pedal. Move feed lever up and step on the foot pedal to relieve the twist and retract excess cable back into the drum, then continue.
7. If you cannot get the cable around a bend, you may be using too large of a cable. Switch to a smaller cable or a smaller machine. (See Cable Application Chart – Table 1)
8. When the cable reaches the stoppage, move the feed lever toward neutral to allow the cable to progress forward slowly, chewing into the stoppage as it goes. This slow forward movement will reduce stress on the cable while doing a more thorough cleaning job. A back and forth motion often works best.

Hint: It's often helpful to have a small stream of water running in the line to wash the cuttings away while the machine is in operation and after.

9. Be careful not to let the cutter get caught in the stoppage as you work through it. This can cause kinking and breaking of the cable. When you feel the cable starting to twist, stop the machine and retract the cable. This will free the cutter from the obstruction. Then allow the cable to move forward slowly into the stoppage.
10. After the line has been opened, retract the cable by moving the feed lever up. Make sure the motor switch is in the **forward** position.
11. When you hear the end of the cable near the drain opening, take your foot off the pedal to stop drum rotation. Never retract the cutter from the drain while cable is rotating. The cable could whip and cause serious injury. Do not retract cutter into Guide Tube.

DO NOT USE REVERSE TO PULL THE CABLE OUT OF THE DRAIN. RUNNING MACHINE IN REVERSE CAN CAUSE THE CABLE TO TANGLE IN THE DRUM.

SPECIAL OPERATIONS

IF CABLE GETS CAUGHT IN LINE

The motor can be reversed for a few seconds at a time to free the cable if it gets caught in line. (Note: if using Power Cable Feed, putting motor in reverse will cause the feed control lever to operate opposite of normal.)

1. Move motor switch to the reverse position.
2. Step on the foot pedal while retracting on the cable.
3. After cable is loose, move motor switch back into forward position.

DO NOT RUN MOTOR IN REVERSE FOR MORE THAN A FEW SECONDS AT A TIME SINCE THIS COULD CAUSE THE CABLE TO KINK OR TANGLE IN THE DRUM.

IF CABLE TANGLES IN DRUM

This can be caused by using too much pressure, running the machine in reverse, or a poorly lubricated or frozen roller in the feed. To untangle the cable, rotate the drum in the opposite direction (See Feed Maintenance). This will usually get the cable to lie in the drum properly.

If the cable has become badly tangled, which shouldn't occur if used properly, it may be necessary to pull the entire cable out of the drum and reinstall it. (See "How to Install Cable" section.)

HOW TO INSTALL CABLE IN DRUM



DISCONNECT MACHINE FROM POWER SOURCE BEFORE INSTALLING CABLE IN DRUM!

1. Connect the male end of the cable to the drum connecting cable already attached to the drum.
2. Remove the V-Belt.
3. Be certain that the cable goes into the drum as shown in the illustration, or the cable will tangle in the drum.
4. Replace the V-Belt after cable is installed.

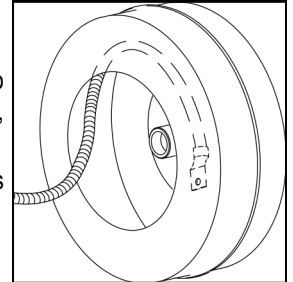

NOTE: The cable must lay in the drum in the correct direction or it will tangle in the drum.

HOW TO REMOVE DRUM



DISCONNECT MACHINE FROM POWER SOURCE BEFORE REMOVING DRUM!

1. Remove belt guard by loosening the knob above the motor and pulling the guard forward.
2. Push the motor down far enough to slide the V-Belt off the drum.
3. Remove the cutter and connecting screw from the cable end.
4. Loosen the knob at the top of the Power Cable Feed.
5. Unscrew the knob behind the front post and pull the Power Cable Feed off the machine.
6. With one hand on the cable, loosen the knob on the front post cap, then open clamp. The Flexitube may spring up out of the clamp. (See Figure 1.)
7. Tip the Speedrooter on its side, opposite to the brake handle.
8. Remove the drum retaining bolt and washers with 3/4" socket with extension.
9. Stand behind the machine, lift the frame slightly off the ground, and slide the frame away from the drum until the drum is off the shaft.
10. Then, roll the drum away from the machine.

Figure 1

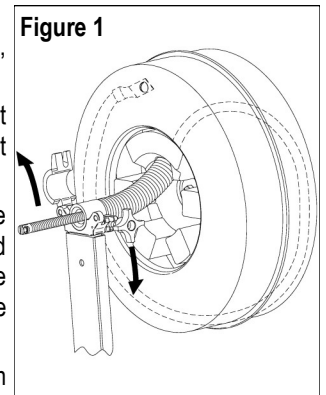

HOW TO INSTALL DRUM



**DISCONNECT MACHINE FROM POWER SOURCE
BEFORE INSTALLING DRUM!**

1. To install the inner drum, pull approximately 12 inches of cable from the drum. Grease the inner drum bushing. Slide the cable through the hole in the inner drum as shown in Figure 2. Slide the inner drum onto the drum hub bushing.

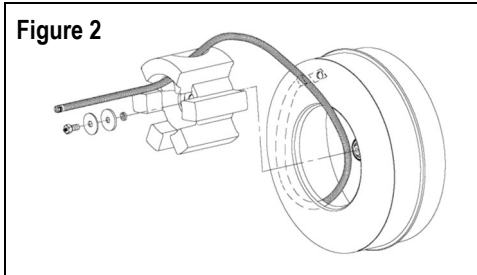

2. Lay the machine frame on its side and roll the drum, with inner drum installed, between the front post and drum shaft. Be sure the front of the drum is facing the front post.
3. While standing behind the frame, line the drum shaft up with the hole in the back of drum, slightly lift the frame, and slide the drum shaft into the back of the drum until the drum contacts the thrust washer on the shaft. Make sure the needle roller bearings inside the hub of the drum stay in place.
4. Make sure that the three washers are still on the drum retaining bolt and thread the bolt into the drum shaft, just finger tight.
5. Stand the machine upright, then tighten the retaining bolt with a 3/4" socket with extension.
6. Slide the V-Belt over the drum (64" for large drum; 59" for small drum) and hang it from the motor pulley (or slip clutch). Push down on the motor enough to slide the V-Belt onto the drum.
7. Pull about 12" of cable out beyond the front post.

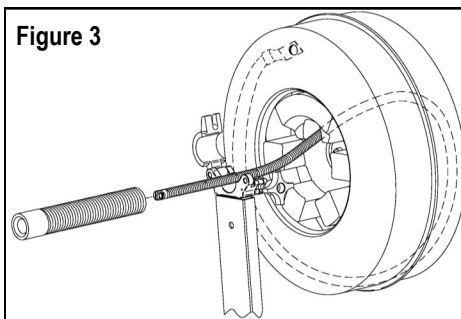

8. Slide the Flexitube, spring end first, onto the cable and into the inner drum. (See Figure 3)
9. Then guide the knurled portion of the Flexitube spring into the front post clamp. (See photo)
10. With one hand on the cable in front of the front post, push the cable down to secure the Flexitube in position within the clamp. Make sure the hole in the Flexitube seats properly over the guide pin in the base of the clamp.



11. Then close the clamp and tighten the knob with your other hand.
12. Slide the Power Cable Feed over the cable and align the bolt with the hole in the front post and the guide pins with the holes on the clamp. When flush with the front post, secure with knob and washer behind the front post.
13. Slide the belt guard over the stud on top of the motor and tighten the knob.

MAINTENANCE



**DISCONNECT MACHINE FROM POWER SOURCE
BEFORE PERFORMING MAINTENANCE!**

To keep your machine operating smoothly, it is essential that all bearings be lubricated. Oiling moving parts is particularly important where machine comes in contact with sand, grit and other abrasive material.

CABLE MAINTENANCE

To get maximum service from your cables, be sure they are clean and well oiled. This not only provides running lubrication but greatly extends the life of the cables as well. Some users periodically pour oil directly into the drum. Then, as the drum turns, the cables get complete lubrication. Our SNAKE OIL is ideally suited for this purpose, since it not only lubricates the cables, it deodorizes them as well.



FEED MAINTENANCE

Keep feed free of excessive soil and grit. It is recommended that the feed be flushed with fresh water followed by a light oiling of the moving parts. No disassembly is normally required. Failure to feed can usually be traced to the following possibilities:

DIRT ACCUMULATION

Over time, dirt can harden enough to stop roller rotation. Flushing with water followed by liberal oiling can usually restore function. If disassembly is required, proceed as follows:

1. Remove the feed pressure knob, cover screws, top cover, ball bearing and ball bearing holder. Note the positioning of these parts to ease re-assembly. Remove the swing pin from the carrier. The top roller assembly can now be removed.
2. Remove the end caps and thrust washers from the bottom housing cylinders. Remove swing pins from carriers. The bottom roller assemblies can now be removed.
3. Re-assembly is done in reverse order.

DAMAGED ROLLER

Excessive use may wear a roller to the point of failure. It is recommended that all three rollers be replaced at the same time (Cat # PO-703). The replacement roller is an assembly consisting of one Feed Roller, two Feed Roller Bearings, and two Bearing Spacers.

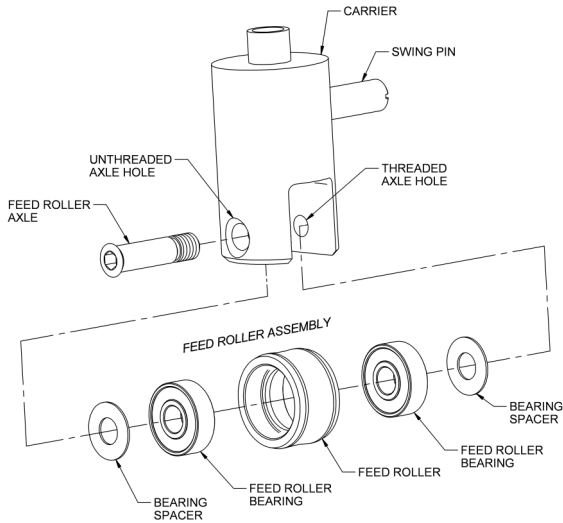

Note: The Bearing Spacers must be installed between the Carrier and each Feed Roller Bearing (as illustrated) in order to ensure proper operation and to obtain maximum Feed Roller life.

To Replace the Feed Roller Assembly:

1. Remove the Feed Roller Assembly by unscrewing and removing the Feed Roller Axle.
2. For convenience, the components are assembled and wired together at the factory. Before attempting to install the assembly, hold the assembly together and remove the wire.
3. While still holding the Feed Roller Assembly together, insert it into the slot opening of the Carrier.
4. In order to help align the Spacers and Bearings, insert a pencil point or similar object through the **un-threaded** end of the Axle hole in the Carrier. After removing the pencil point, continue to maintain the alignment of the components.
5. The Feed Roller Axle should then be inserted through the same un-threaded Axle hole and should continue to be guided through the Spacers and Bearings to the threaded Axle hole on the other side of the Carrier.
6. Securely tighten the Axle to the Carrier with a 3/16" allen wrench.

TANGLED CABLE

If a cable loops over itself in the drum, it will not feed properly. Remove and reload the cable to restore function. If the cable kinks, it is evidence of abuse and results from the use of too much pressure or use of the wrong size cable for the line. Do not force the cable — let the cutter do the work.

TROUBLE SHOOTING GUIDE (Table 3)		
Problem	Probable Cause	Solution
Cable kinks or breaks.	Operator forcing the cable.	Do not force the cable. Let the cutter do the work.
	Too much slack between machine and drain.	Allow no more than two feet between machine and drain.
	Cable used in wrong size drain line.	A cable that is too large or too small in diameter for a line is more likely to kink. (Consult Table 1—Cable Applications.)
	Cable exposed to acid.	Clean and oil cables regularly.
Cable tangles in drum.	Operator forcing the cable.	Do not force the cable. Let the cutter do the work.
	Machine running in reverse.	Do not run the machine in reverse to retract the cable from the drain.
Drum stops while foot pedal depressed.	Hole in pedal or hose.	Replace as required.
	Hole in diaphragm switch.	If no hole found in pedal or hose, replace diaphragm switch.
	Thermal overload activated.	Allow motor to cool. Press reset switch.
Drum turns in one direction but not other.	Reverse switch failure or momentary contact switch.	Replace switch. Note: Momentary contact switch must be held in position to use reverse.
Ground fault circuit interrupter trips and will not reset.	Damaged power cord or extension cord.	Replace cords.
	Short circuit in motor.	Take motor to authorized repair center.
	Faulty ground fault circuit interrupter.	Replace ground fault circuit interrupter.
Motor turns but drum does not.	Safety Slip Clutch (optional) engaged.	Do not force cable.
Failure to feed.	Cable tangled in drum.	Do not run machine in reverse. Use proper cable size. (Consult Cable Application Chart—Table 1).
	Feed misadjusted.	If feed tension knob is too loose the cable will slip. If it is too tight the feed rollers will wear prematurely.
	Feed roller frozen.	Clean and lubricate feed rollers regularly. Replace worn rollers.
	Worn cable.	When cable coils wear flat, cable should be replaced.

SPEEDROTER 92 PARTS LIST

CAT. NO.	DESCRIPTION	CAT. NO.	DESCRIPTION
S92-100	Frame Complete w/Axle	S92-602-2	Slip Clutch (Optional)
S92-101	Frame Only w/Axle	S92-603	Knob for Belt Guard
S92-101-A	Handle Support Knob (2)	GFI-20	20 ft. Power Cord w/GFCI
S92-103	Stair Climber w/Belt (1)	S92-605	Air Foot Switch & Reverse Switch Assembly
S92-103-A	Nuts, Bolt, & Washers (2)	S92-605-A	Box Only w/Cover & Screws
S92-103-B	Spacers (2)	S92-605-B	Foot Pedal & Hose
S92-107	Handle Assembly	S92-605-C	Hose Clamp
S92-107-A	Handle - Left	S92-605-E	Power Switch Diaphragm
S92-107-B	Handle - Right	S92-605-G	Reverse Switch - 3-Way
S92-107-C	6" Handle Wheel	S92-605-K	Switch Guard
S92-107-D	Axle for Handle Wheel	S92-605-N	Strain Relief Nut
S92-107-E	Bushings (2)	S92-606	Belt Guard Washer
S92-107-F	Felt Washers (2)	S92-609-1/2	Belt Guard (1/2 hp) w/Slot
S92-107-G	Bolts & Nuts (2)	S92-605-3/4	Belt Guard (3/4 hp) w/Slot
S92-107-H	Set Screws (2)	S92-614	Small Drum (15") V-Belt (57")
S92-107-J	Rubber Cord Wrap Tip	S92-614-1	Small Drum (16") V-Belt (59")
S92-109-A	Knob for Brake Rod	S92-7000	Power Cable Feed Assembly
S92-109-C	Brake Rod Latch w/Screws	S92-7101	Feed Body
S92-110	10" Wheel w/Retaining Cap (1)	S92-7101-1	Feed Body for One Piece Feed Control Disk
S92-111	Wheel Retaining Cap (2)	S92-7101-A	Lifting Spring
S92-112	Axle Spacer (2)	S92-7101-B	Guide Pins (2)
S92-113	Wheel Spacer Washers	S92-7102	Mounting Stud
S92-115	Axle	S92-7103	Mounting Knob
S92-116	Motor Support Spring	S92-7104	Spout & Retaining Cover
S92-118	Motor Support Platform	S92-7104-1	Spout for One Piece Feed Control Disk
S92-118-B	Guide Screws (2)	S92-7105	Steel Washer
S92-118-C	Nuts, Bolt, & Washers (4)	S92-7200	Top Roller Assembly
S92-120	Front Bearing Assembly	S92-7210	Top Carrier Only
S92-120-A	Front Bearing Knob	S92-7220	Swing Pin
S92-120-D	Bolts, Nuts, & Washers (2)	S92-7225	Feed Roller Shaft
S92-180	Drum Shaft	S92-7250	Feed Roller w/Bearing
S92-180-A	Wear Washer	S92-7301	Feed Pressure Knob
S92-181-1	Drum Shaft Retaining Bolt w/Grease Fitting	S92-7301-A	Limiting Nut
S92-182	Retaining Washer	S92-7315	Pressure Spring
S92-183	Felt Washer	S92-7330	Ball Bearing
S92-200	Spring Distributor Tube	S92-7331	Ball Bearing Holder
S92-400-1	Small Drum Complete (16")	S92-7340	Top Cover
S92-402-1	Drum Shell (16")	S92-7341	Cover Screws (3)
S92-410	Drum Connecting Cable (for 1/2" Cables)	S92-7400	Bottom Roller Assembly
S92-410-A	Nut, Bolt, & Washer	S92-7410	Bottom Carrier Only
S92-440	Inner Drum Cage for 15" Small Drum	S92-7420	Swing Pin
S92-440-1	Inner Drum Cage for 16" Small Drum	S92-7425	Bottom Roller Shaft
S92-450	Large Drum Complete	S92-7450	Bottom Roller w/Bearing
S92-452	Drum Shell	S92-7530	Thrust Bearing
S92-454	Drum Hub Bearings (2)	S92-7540	Cable Adjustment Plate
S92-456	Bushing	S92-7541	Plate Screws (3)
S92-460	Drum Connecting Cable (for 5/8" & 3/4" Cables)	S92-7601	Feed Control Disc w/Lever & Knob
S92-460-A	Nut, Bolt, & Washer	S92-7601-A	Lever & Knob
S92-490	Inner Drum Cage for Large Drum	S92-7601-1	Feed Control Disk (One Piece)
S92-490-B	Inner Drum Cage Bushing	S92-7635	Wave Washer
S92-490-C	Screws & Washers (3)	S92-7635-1	Wave Washer for One Piece Feed Control Disk
S92-600	1/2 hp Motor Complete w/Air Foot Switch, Reverse Switch, & GFCI	PO-703	Set of Feed Rollers (3)
S92-600-3/4	3/4 hp Motor Complete w/Air Foot Switch, Reverse Switch, & GFCI	S92-TB	Tool Box w/Bolts & Nuts
S92-601	V-Belt (64")	S92-GT	Guide Tube
S92-602	V-Belt Pulley	GTE	Guide Tube Extension
		S92-DECAL	Set of Safety Decals
		S92-DVD	Instructional DVD

SPEEDROTER 92 SCHEMATIC DIAGRAM

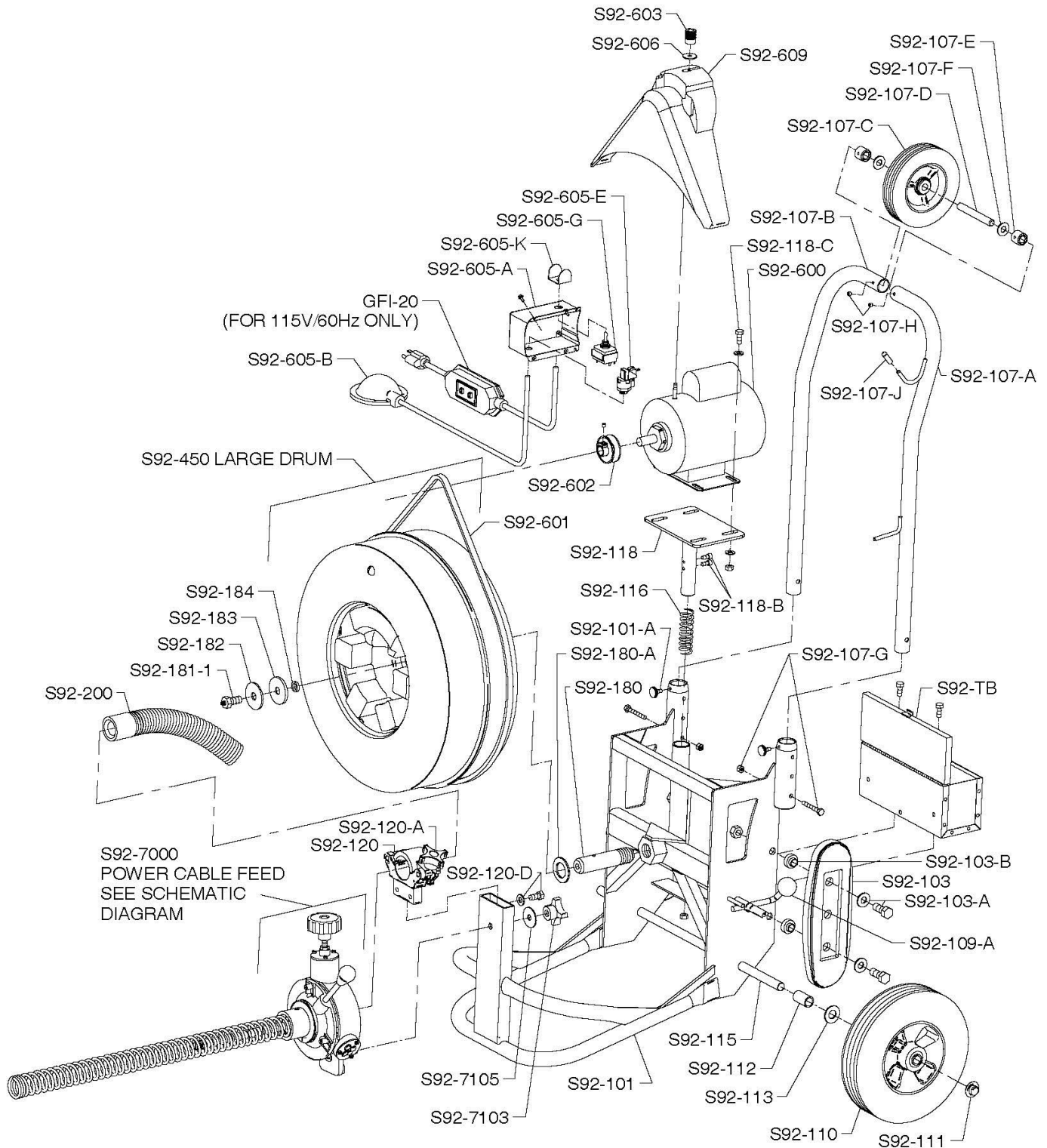

IMPORTANT: When ordering, give Serial Number of Machine.

SPEEDROTER 92 SCHEMATIC DIAGRAM

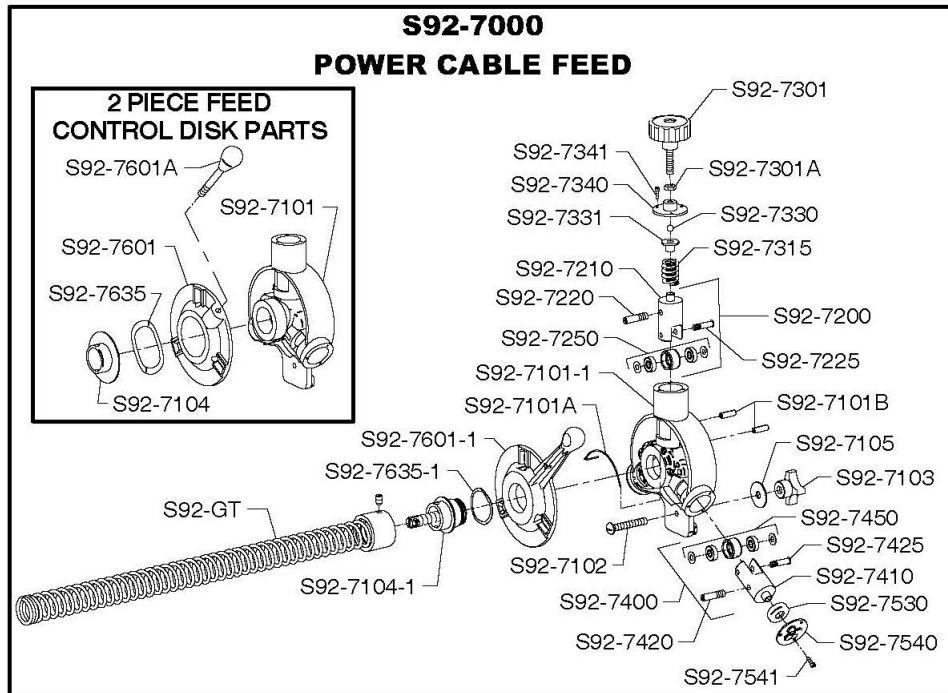
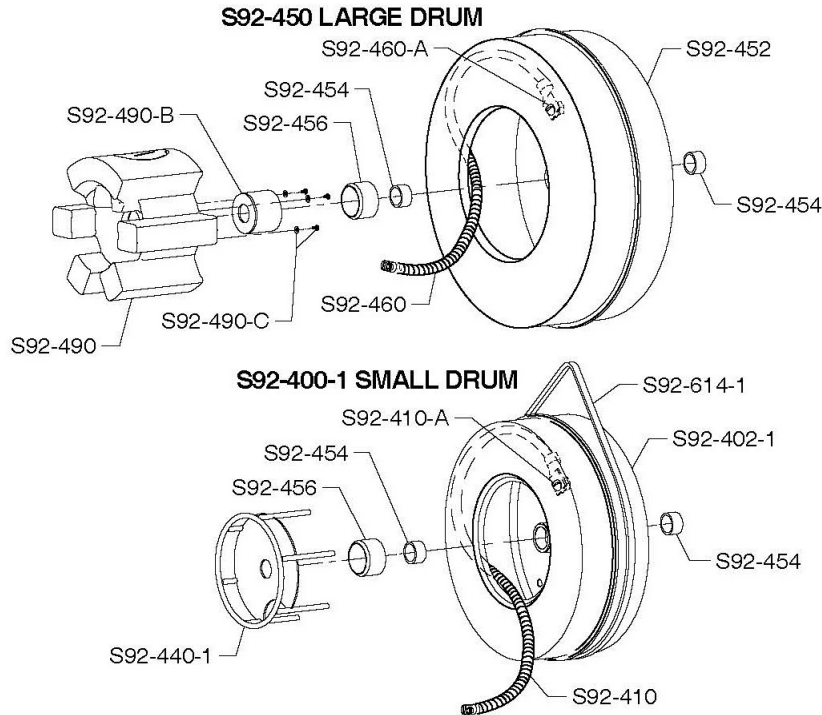

IMPORTANT: When ordering, give Serial Number of Machine.

**General Wire Spring Co,
1101 Thompson Avenue
McKees Rocks, PA 15136**

412-771-6300

www.drainbrain.com